

Lifting Capacities

Hydraulic Rough Terrain Crane

RTC-8030 30-ton (27.22 metric ton)

4-Section Boom

Working Range shown is for machine with fully extended outriggers. For working ranges of machine with intermediate (half extended) outriggers, fully retracted outriggers or on tires see Crane Rating Manual in machine.

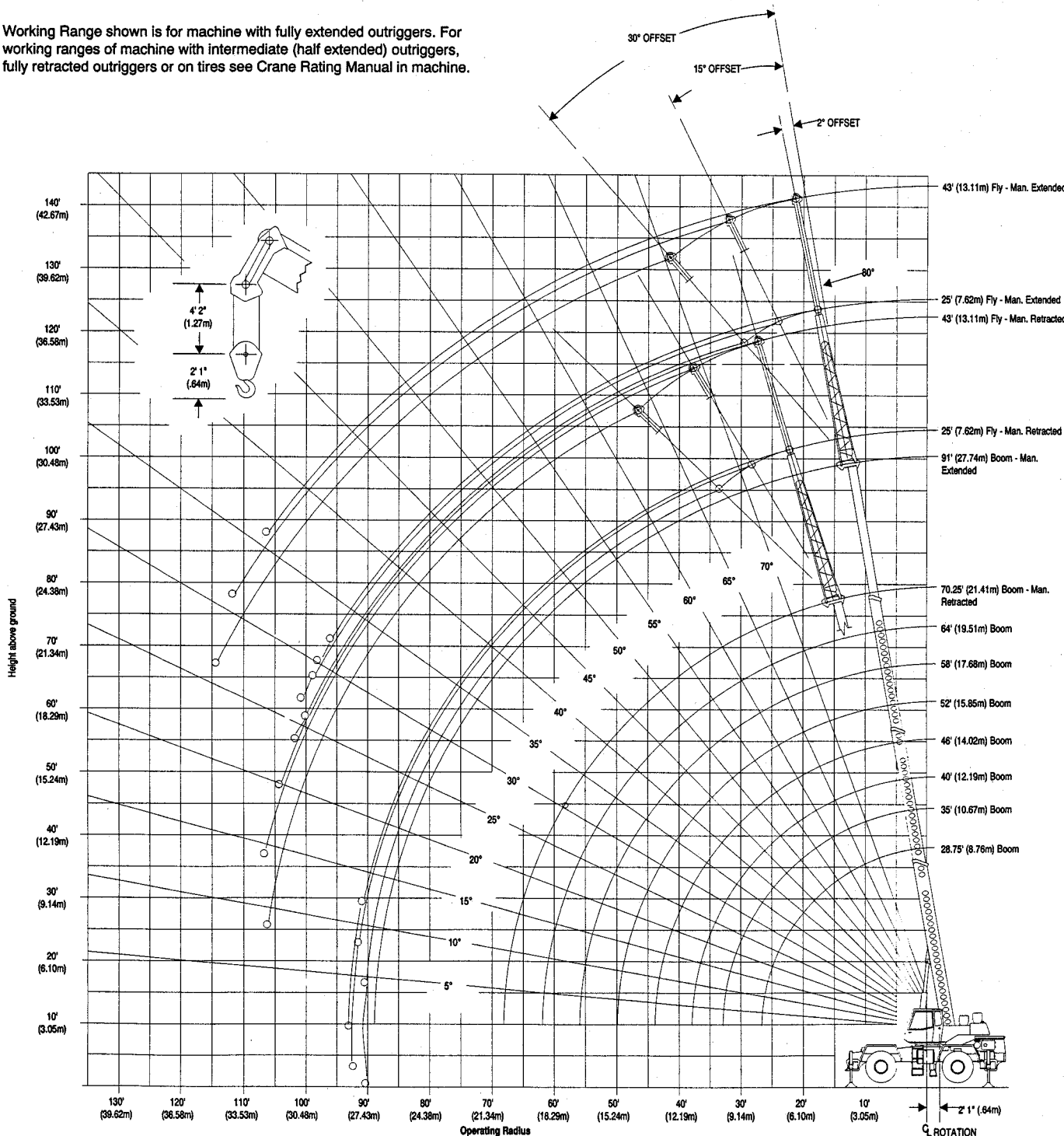

Note: Boom and fly geometry shown are for unloaded condition and machine standing level on firm supporting surface. Boom deflection and subsequent radius and boom angle change must be accounted for when applying load to hook.

RTC-8030 Lifting Capacities

Refer to Operating Instructions page 1

28.75' - 91' (8.76m - 27.74m) 4-section boom - Outriggers Fully Extended

Outriggers Fully Extended																			
28.75' (8.76m) TO 58' (17.68m) Main Boom with Manual Retracted																			
LOAD RADIUS (ft./m)	28.75' (8.76m)			35' (10.67m)			40' (12.19m)			46' (14.02m)			52' (15.85m)			58' (17.68m)			
	LOADED BOOM ANGLE (deg.)	360° (lbs./kgs)	OVER FRONT (lbs./kgs)	LOADED BOOM ANGLE (deg.)	360° (lbs./kgs)	OVER FRONT (lbs./kgs)	LOADED BOOM ANGLE (deg.)	360° (lbs./kgs)	OVER FRONT (lbs./kgs)	LOADED BOOM ANGLE (deg.)	360° (lbs./kgs)	OVER FRONT (lbs./kgs)	LOADED BOOM ANGLE (deg.)	360° (lbs./kgs)	OVER FRONT (lbs./kgs)	LOADED BOOM ANGLE (deg.)	360° (lbs./kgs)	OVER FRONT (lbs./kgs)	LOAD RADIUS (ft./m)
10	66.0	60,000	60,000	70.5	48,600	48,600	73.5	47,800	47,800	76.0	47,200	47,200	78.0	46,800	46,800				10
3.05		27 216	27 216		22 045	22 045		21 682	21 682		21 410	21 410		21 228	21 228				3.05
12	61.5	54,000	54,000	67.0	48,600	48,600	70.5	47,800	47,800	73.5	47,200	47,200	76.0	43,800	43,800	77.5	40,200	40,200	12
3.66		24 494	24 494		22 045	22 045		21 682	21 682		21 410	21 410		19 868	19 868		18 235	18 235	3.66
15	54.5	42,900	42,900	61.5	42,800	42,800	66.0	42,800	42,800	69.5	41,500	41,500	72.5	37,600	37,600	74.5	34,900	34,900	15
4.57		19 459	19 459		19 414	19 414		19 414	19 414		18 824	18 824		17 055	17 055		15 831	15 831	4.57
20	40.5	30,700	30,700	52.0	30,700	30,700	57.5	30,700	30,700	62.5	30,700	30,700	66.5	30,300	30,300	69.5	28,000	28,000	20
6.10		13 926	13 926		13 926	13 926		13 926	13 926		13 926	13 926		13 744	13 744		12 701	12 701	6.10
25	20.5	22,700	22,700	40.0	22,700	22,700	48.5	22,700	22,700	55.0	22,700	22,700	60.0	22,700	22,700	64.0	22,700	22,700	25
7.62		10 297	10 297		10 297	10 297		10 297	10 297		10 297	10 297		10 297	10 297		10 297	10 297	7.62
30				24.5	18,500	18,500	37.5	18,500	18,500	47.0	18,500	18,500	53.5	18,500	18,500	58.0	18,500	18,500	30
9.14					8 392	8 392		8 392	8 392		8 392	8 392		8 392	8 392		8 392	8 392	9.14
35							23.0	14,600	15,100	37.5	14,600	15,100	46.0	14,600	15,100	52.0	14,600	15,100	35
10.67								6 623	6 849		6 623	6 849		6 623	6 849		6 623	6 849	10.67
40										25.0	11,400	12,500	37.5	11,400	12,500	45.0	11,400	12,500	40
12.19											5 171	5 670		5 171	5 670		5 171	5 670	12.19
45													26.5	9,100	10,500	37.5	9,100	10,500	45
13.72														4 128	4 763		4 128	4 763	13.72
50																27.5	7,400	8,900	50
15.24																	3 357	4 037	15.24
0 Angle Capacity		12,000	13,200		8,100	9,900		6,200	8,100		4,700	6,400		3,600	5,200		2,800	4,200	
		5 443	5 988		3 674	4 491		2 812	3 674		2 132	2 903		1 633	2 359		1 270	1 905	

Outriggers Fully Extended										
64' (19.51m) TO 70.25' (21.41m) Main Boom										
LOAD RADIUS (ft./m)	Manual Retracted						Manual Extended			LOAD RADIUS (ft./m)
	64' (19.51m)		70.25' (21.41m)		91' (27.74m)					
LOADED BOOM ANGLE (deg.)	360° (lbs./kgs)	OVER FRONT (lbs./kgs)	LOADED BOOM ANGLE (deg.)	360° (lbs./kgs)	OVER FRONT (lbs./kgs)	LOADED BOOM ANGLE (deg.)	360° (lbs./kgs)	OVER FRONT (lbs./kgs)	LOAD RADIUS (ft./m)	
15	76.5	32,100	32,100	78.0	28,500	28,500			15	
4.57		14 561	14 561		12 928	12 928			4.57	
20	72.0	26,400	26,400	74.0	24,100	24,100	79.0	18,600	20	
6.10		11 975	11 975		10 932	10 932		8 437	6.10	
25	67.0	21,900	21,900	70.0	20,700	20,700	75.5	16,300	25	
7.62		9 934	9 934		9 390	9 390		7 394	7.62	
30	62.0	18,500	18,500	65.5	17,600	17,600	72.5	14,500	30	
9.14		8 392	8 392		7 983	7 983		6 577	9.14	
35	56.5	14,600	15,100	60.5	14,600	15,100	69.0	12,900	35	
10.67		6 623	6 849		6 623	6 849		5 851	10.67	
40	51.0	11,400	12,500	55.5	11,400	12,500	66.0	11,400	40	
12.19		5 171	5 670		5 171	5 670		5 171	12.19	
45	44.5	9,100	10,500	50.0	9,100	10,500	62.5	10,100	45	
13.72		4 128	4 763		4 128	4 763		4 581	13.72	
50	37.5	7,400	8,900	44.5	7,400	8,900	58.5	8,400	50	
15.24		3 357	4 037		3 357	4 037		3 810	15.24	
55	28.5	6,000	7,600	37.5	6,000	7,600	54.5	7,000	55	
16.76		2 722	3 447		2 722	3 447		3 175	16.76	
60	15.5	4,900	6,500	30.0	4,900	6,500	50.5	5,900	60	
18.29		2 223	2 948		2 223	2 948		2 676	18.29	
65				19.0	4,000	5,500	46.0	4,900	65	
19.81					1 814	2 495		2 223	19.81	
70							41.0	4,200	70	
21.34								1 905	21.34	
75							35.5	3,500	75	
22.86								1 588	22.86	
80							28.5	3,000	80	
24.38								1 361	24.38	
85							20.0	2,500	85	
25.91								1 134	25.91	
0 Angle Capacity		2,200	3,400		1,700	2,800	Minimum Boom Angle For No Load: 0°			
		998	1 542		771	1 270				

Outriggers Fully Extended									
25' (7.62m) Fly									
LOAD RADIUS (ft./m)	25' (7.62m) Fly				25' (7.62m) Fly				LOAD RADIUS (ft./m)
	Manual Retracted		Manual Extended		Manual Retracted		Manual Extended		
LOADED BOOM ANGLE (deg.)	360° (lbs./kgs)	OVER FRONT (lbs./kgs)	LOADED BOOM ANGLE (deg.)	360° (lbs./kgs)	OVER FRONT (lbs./kgs)	LOADED BOOM ANGLE (deg.)	360° (lbs./kgs)	OVER FRONT (lbs./kgs)	LOAD RADIUS (ft./m)
20	78.5	16,200	16,200						20
6.10		7 348	7 348						6.10
25	75.5	13,900	13,900						25
7.62		6 305	6 305						7.62
30	72.5	12,200	12,200	77.5	10,300	10,300			30
9.14		5 534	5 534		4 672	4 672			9.14
35	69.5	10,900	10,900	75.0	9,000	9,000			35
10.67		4 944	4 944		4 082	4 082			10.67
40	66.0	9,800	9,800	72.5	8,100	8,100			40
12.19		4 445	4 445		3 674	3 674			12.19
45	63.0	8,800	8,800	69.5	7,200	7,200			45
13.72		3 992	3 992		3 266	3 266			13.72
50	59.5	8,100	8,100	67.0	6,500	6,500			50
15.24		3 674	3 674		2 948	2 948			15.24
55	55.5	7,100	7,500	64.0	5,900	5,900			55
16.76		3 221	3 402		2 676	2 676			16.76
60	52.0	6,000	7,000	61.5	5,400	5,400			60
18.29		2 722	3 175		2 449	2 449			18.29
65	48.0	5,100	6,400	58.5	5,000	5,000			65
19.81		2 313	2 903		2 268	2 268			19.81
70	43.5	4,300	5,700	55.5	4,600	4,600			70
21.34		1 950	2 586		2 087	2 087			21.34
75	38.5	3,700	5,000	52.0	4,100	4,200			75
22.86		1 678	2 268		1 860	1 905			22.86
80	32.5	3,100	4,400	49.0	3,500	3,900			80
24.38		1 406	1 996		1 588	1 769			24.38
85	26.0	2,700	3,900	45.0	3,000	3,500			85
25.91		1 225	1 769		1 361	1 588			25.91
90	17.0	2,200	3,400	41.5	2,600	3,300			90
27.43		998	1 542		1 179	1 497			27.43
95				37.8	2,300	3,000			95
28.96					1 043	1 361			28.96
100				32.0	1,900	2,800			100
30.48					862	1 270			30.48
105				26.5	1,600	2,600			105
32.00					726	1 179			32.00

Minimum Boom Angle For No Load: 0°
 Warning: Do not lower 25' fixed fly in working position below 13 degrees unless main boom length is 88' or less, since loss of stability will occur causing a tipping condition.

RTC-8030 Lifting Capacities

Refer to Operating Instructions page 12

28.75' - 91' (8.76m - 27.74m) 4-section boom - Outriggers Fully Extended

Outriggers Fully Extended													
LOAD RADIUS (ft./m)	25' (7.62m) Offsettable Fly - manual retracted						25' (7.62m) Offsettable Fly - manual extended						
	2° OFFSET		15° OFFSET		30° OFFSET		2° OFFSET		15° OFFSET		30° OFFSET		
	LOADED BOOM ANGLE (deg.)	LOAD (lbs./kgs)	LOADED BOOM ANGLE (deg.)	LOAD (lbs./kgs)	LOADED BOOM ANGLE (deg.)	LOAD (lbs./kgs)	LOADED BOOM ANGLE (deg.)	LOAD (lbs./kgs)	LOADED BOOM ANGLE (deg.)	LOAD (lbs./kgs)	LOADED BOOM ANGLE (deg.)	LOAD (lbs./kgs)	
20 6.10	78.5	13,000 5 897										20 6.10	
25 7.62	75.5	11,900 5 398	79.0	9,100 4 128			79.5	10,300 4 672				25 7.62	
30 9.14	72.5	10,900 4 944	76.0	8,500 3 856	79.0	6,400 2 903	77.0	9,100 4 128	80.0	8,400 3 810		30 9.14	
35 10.67	69.5	9,800 4 445	73.0	7,800 3 538	76.0	6,000 2 722	75.0	8,100 3 674	77.5	7,400 3 357	80.0	6,400 2 903	35 10.67
40 12.19	66.5	9,200 4 173	69.5	7,200 3 266	72.5	5,700 2 586	72.5	7,300 3 311	75.0	6,600 2 994	77.5	5,900 2 676	40 12.19
45 13.72	63.0	8,500 3 856	66.0	6,600 2 994	69.5	5,400 2 449	70.0	6,800 2 994	72.5	5,900 2 676	75.0	5,300 2 404	45 13.72
50 15.24	59.5	7,700 3 493	62.5	6,100 2 767	65.5	5,200 2 359	67.0	5,900 2 676	70.0	5,300 2 404	72.5	4,900 2 223	50 15.24
55 16.76	56.0	6,800 3 084	59.0	5,800 2 631	62.0	4,900 2 223	64.5	5,400 2 449	67.0	4,800 2 177	69.5	4,500 2 041	55 16.76
60 18.29	52.0	5,700 2 586	55.0	5,400 2 449	58.0	4,700 2 132	61.5	4,900 2 223	64.0	4,400 1 996	66.5	4,100 1 860	60 18.29
65 19.81	48.0	4,800 2 177	51.0	5,100 2 313	54.0	4,600 2 087	58.5	4,500 2 041	61.0	4,100 1 860	63.5	3,800 1 724	65 19.81
70 21.34	43.5	4,000 1 814	46.5	4,300 1 950	49.0	4,300 1 950	55.5	4,100 1 860	58.0	3,700 1 678	60.5	3,500 1 588	70 21.34
75 22.86	38.5	3,400 1 542	41.5	3,600 1 633	44.0	3,700 1 678	52.0	3,700 1 678	55.0	3,400 1 542	57.0	3,300 1 497	75 22.86
80 24.38	33.0	2,800 1 270	36.0	3,000 1 361	38.0	3,100 1 406	49.0	3,200 1 452	51.5	3,200 1 452	53.5	3,100 1 406	80 24.38
85 25.91	26.5	2,400 1 089	29.0	2,400 1 089	30.0	2,500 1 134	45.0	2,700 1 225	48.0	2,900 1 315	49.5	2,900 1 315	85 25.91
90 27.43	17.5	1,900 862	19.5	2,000 907	17.0	1,900 862	41.0	2,300 1 043	44.0	2,400 1 089	45.5	2,500 1 134	90 27.43
95 28.96							37.0	1,900 862	39.5	2,000 907	41.0	2,100 953	95 28.96
100 30.48							32.0	1,600 726	34.5	1,700 771	35.5	1,700 771	100 30.48
105 32.00							28.5	1,300 590	29.5	1,400 635	29.5	1,400 635	105 32.00
Minimum Boom Angle For No Load: 0°							Warning: Do not lower 25' fixed fly in working position below 13 degrees unless main boom length is 81' or less, since loss of stability will occur causing a tipping condition.						

RTC-8030 Lifting Capacities

Refer to Operating Instructions page 12

28.75' - 91' (8.76m - 27.74m) 4-section boom - Outriggers Fully Extended

Outriggers Fully Extended													
25' - 43' (7.62m - 13.11m) Offset Telescoping Fly + 70.25' (21.41m) Main Boom with Manual Retracted													
LOAD RADIUS (ft./m)	25' (7.62m) Fly						43' (13.11m) Fly						LOAD RADIUS (ft./m)
	2° OFFSET		15° OFFSET		30° OFFSET		2° OFFSET		15° OFFSET		30° OFFSET		
	LOADED BOOM ANGLE (deg.)	LOAD (lbs./kgs)	LOADED BOOM ANGLE (deg.)	LOAD (lbs./kgs)	LOADED BOOM ANGLE (deg.)	LOAD (lbs./kgs)	LOADED BOOM ANGLE (deg.)	LOAD (lbs./kgs)	LOADED BOOM ANGLE (deg.)	LOAD (lbs./kgs)	LOADED BOOM ANGLE (deg.)	LOAD (lbs./kgs)	
20 6.10	78.5	12,700 5 761											20 6.10
25 7.62	75.5	11,500 5 216	79.0	8,800 3 992			77.5	4,900 2 223					25 7.62
30 9.14	72.5	10,600 4 808	76.0	8,200 3 720	79.0	6,100 2 767	75.5	4,700 2 132					30 9.14
35 10.67	69.5	9,600 4 355	73.0	7,500 3 402	76.0	5,700 2 586	73.0	4,500 2 041	78.0	4,000 1 814			35 10.67
40 12.19	66.0	8,700 3 946	69.5	6,900 3 130	72.5	5,400 2 449	70.0	4,300 1 950	75.5	3,900 1 789			40 12.19
45 13.72	63.0	8,000 3 629	66.0	6,400 2 903	69.0	5,100 2 313	67.5	4,100 1 860	72.5	3,700 1 678	77.5	3,000 1 361	45 13.72
50 15.24	59.5	7,400 3 357	62.5	5,900 2 676	65.5	4,800 2 177	65.0	3,900 1 769	70.0	3,500 1 588	74.5	2,900 1 315	50 15.24
55 16.76	56.0	6,500 2 948	59.0	5,300 2 404	62.0	4,500 2 041	62.0	3,800 1 724	67.0	3,300 1 497	71.5	2,700 1 225	55 16.76
60 18.29	52.0	5,400 2 449	55.0	4,900 2 223	58.0	4,200 1 905	59.5	3,700 1 678	64.0	3,100 1 406	68.5	2,600 1 179	60 18.29
65 19.81	48.0	4,500 2 041	51.0	4,500 2 041	53.5	3,900 1 769	56.5	3,500 1 588	61.0	2,900 1 315	65.5	2,500 1 134	65 19.81
70 21.34	43.5	3,700 1 678	46.5	3,900 1 769	49.0	3,600 1 633	53.5	3,200 1 452	58.0	2,800 1 270	62.5	2,400 1 089	70 21.34
75 22.86	38.5	3,000 1 361	41.5	3,200 1 452	44.0	3,400 1 542	50.0	3,000 1 361	54.5	2,600 1 179	59.0	2,300 1 043	75 22.86
80 24.38	33.0	2,500 1 134	36.0	2,600 1 179	37.5	2,700 1 225	46.5	2,800 1 270	51.0	2,500 1 134	55.0	2,200 998	80 24.38
85 25.91	26.5	2,000 907	29.0	2,100 953	30.0	2,100 953	43.0	2,700 1 225	47.5	2,400 1 089	51.0	2,100 953	85 25.91
90 27.43	17.5	1,600 726	19.5	1,600 726	17.0	1,600 726	38.5	2,300 1 043	43.0	2,300 1 043	46.5	2,000 907	90 27.43
95 28.96							34.0	2,000 907	38.5	2,200 998	41.5	2,000 907	95 28.96
100 30.48							28.5	1,600 726	33.0	1,800 816	35.5	1,900 862	100 30.48
105 32.00									25.5	1,400 635	26.0	1,400 635	105 32.00

Warning: Do not lower 25' offset telescoping fly in working position below 12° unless main boom length is 68' or less, since loss of stability will occur causing a tipping condition.

Warning: Do not lower 43' offset telescoping fly in working position below 20° unless main boom is 65' or less, since loss of stability will occur causing a tipping condition.

Drum wire rope capacities

Wire Rope Layer	Capacity		Capacity	
	Rope Per Layer		Total Wire Rope	
	Feet	Meters	Feet	Meters
1	62	18.90	62	18.90
2	69	21.03	131	39.93
3	76	23.16	206	62.79
4	82	25.00	289	88.09
5	89	27.13	378	115.21

Capacity Deductions for Auxiliary Load Handling Equipment. Lifting from Main Boom with:

Aux. Equipment	Deduct
Aux. Head Attached	125 lbs. (56.70 kg)
25' (7.62m) Fixed Fly Stowed On Base	300 lbs. (136.08 kg)
25' (7.62m) Fixed Fly Erected But Unused	1,000 lbs. (453.60 kg)
25' (7.62m) Offset Fly Stowed On Base	500 lbs. (226.80 kg)
25' (7.62m) Offset Fly Erected But Unused	2,200 lbs. (997.92 kg)
25' - 43' (7.62m - 13.11m) Offset Telescoping Fly Stowed On Base	750 lbs. (340.20 kg)
25' - 43' (7.62m - 13.11m) Offset Telescoping Fly Erected But Unused (retracted)	2,900 lbs. (1315.44 kg)
25' - 43' (7.62m - 13.11m) Offset Telescoping Fly Erected But Unused (extended)	3,900 lbs. (1769.04 kg)

RTC-8030 Lifting Capacities

Refer to Operating Instructions page 12

28.75' - 91' (8.76m - 27.74m) 4-section boom - Outriggers Fully Extended

Outriggers Fully Extended													
25' - 43' (7.62m - 13.11m) Offset Telescoping Fly + 91' (27.74m) Main Boom													
LOAD RADIUS (ft./m)	25' (7.62m) Fly						43' (13.11m) Fly						LOAD RADIUS (ft./m)
	2° OFFSET		15° OFFSET		30° OFFSET		2° OFFSET		15° OFFSET		30° OFFSET		
	LOADED BOOM ANGLE (deg.)	LOAD (lbs./kgs)	LOADED BOOM ANGLE (deg.)	LOAD (lbs./kgs)	LOADED BOOM ANGLE (deg.)	LOAD (lbs./kgs)	LOADED BOOM ANGLE (deg.)	LOAD (lbs./kgs)	LOADED BOOM ANGLE (deg.)	LOAD (lbs./kgs)	LOADED BOOM ANGLE (deg.)	LOAD (lbs./kgs)	
25 7.62	79.5	9,900 4 491											25 7.62
30 9.14	77.0	8,700 3 946	80.0	8,000 3 629									30 9.14
35 10.67	75.0	7,700 3 493	77.5	7,000 3 175	80.0	6,000 2 722	78.0	4,900 2 223					35 10.67
40 12.19	72.5	6,900 3 130	75.0	6,200 2 812	77.5	5,500 2 495	75.5	4,700 2 132	79.0	4,000 1 814			40 12.19
45 13.72	70.0	6,100 2 767	72.5	5,500 2 495	75.0	5,000 2 268	73.5	4,500 2 041	77.5	3,900 1 769			45 13.72
50 15.24	67.0	5,500 2 495	70.0	4,900 2 223	72.5	4,500 2 041	71.5	4,300 1 950	75.5	3,700 1 678	79.0	3,100 1 406	50 15.24
55 16.76	64.5	4,900 2 223	67.0	4,500 2 041	69.5	4,100 1 860	69.0	3,900 1 769	73.0	3,400 1 542	77.0	3,000 1 361	55 16.76
60 18.29	61.5	4,400 1 996	64.0	4,000 1 814	66.5	3,700 1 678	66.5	3,500 1 588	70.5	3,100 1 406	74.5	2,800 1 270	60 18.29
65 19.81	58.5	4,000 1 814	61.0	3,700 1 678	63.5	3,400 1 542	64.5	3,100 1 406	68.0	2,800 1 270	72.0	2,600 1 179	65 19.81
70 21.34	55.5	3,600 1 633	58.0	3,400 1 542	60.5	3,200 1 452	62.0	2,800 1 270	65.5	2,600 1 179	69.5	2,400 1 089	70 21.34
75 22.86	52.0	3,200 1 452	55.0	3,100 1 406	57.0	2,900 1 315	59.0	2,500 1 134	63.0	2,300 1 043	66.5	2,200 998	75 22.86
80 24.38	49.0	2,800 1 270	51.5	2,800 1 270	53.5	2,700 1 225	56.5	2,300 1 043	60.5	2,100 953	64.0	2,000 907	80 24.38
85 25.91	45.0	2,400 1 089	48.0	2,500 1 134	49.5	2,500 1 134	54.0	2,000 907	58.0	2,000 907	61.0	1,800 816	85 25.91
90 27.43	41.0	1,900 862	44.0	2,100 953	45.5	2,200 998	51.0	1,700 771	54.5	1,700 771	58.0	1,700 771	90 27.43
95 28.96	37.0	1,600 726	39.5	1,700 771	41.0	1,800 816	48.0	1,500 680	51.5	1,600 726	54.5	1,600 726	95 28.96
100 30.48	32.0	1,200 544	34.5	1,300 590	35.5	1,400 635	45.0	1,300 590	48.5	1,400 635	51.5	1,400 635	100 30.48
105 32.00							41.0	1,100 499	45.0	1,200 544	48.0	1,200 544	105 32.00
110 33.53							37.5	900 408	41.0	1,000 454	43.5	1,100 499	110 33.53
115 35.05								900 408	37.0	900 408	39.0	900 408	115 35.05

Warning: Do not lower 25' offset telescoping fly in working position below 32° unless main boom length is 76' or less, since loss of stability will occur causing a tipping condition.

Warning: Do not lower 43' offset telescoping fly in working position below 36° unless main boom is 72' or less, since loss of stability will occur causing a tipping condition.

Line Speeds and Pulls

Wire Rope	1M Main or Auxiliary Winch 10-5/8" (.27m) diameter drum				2M Main or Auxiliary Winch 10-5/8" (.27m) diameter drum				
	Line Speeds		Available Line Pulls		Speed	Line Speeds		Available Line Pulls	
	(fpm)	(m/min)	(lbs.)	(kgs)		(fpm)	(m/min)		(lbs.)
1	159	48.46	10,547	4 748	Low	162	49.38	10,360	4 699
					High	270	82.30	5,744	2 605
2	176	53.64	9,492	4 305	Low	180	54.86	9,325	4 230
					High	300	91.44	5,170	2 345
3	194	59.13	8,630	3 915	Low	197	60.05	8,477	3 845
					High	330	100.58	4,700	2 132
4	212	64.62	7,911	3 588	Low	215	65.53	7,771	3 525
					High	360	109.73	4,309	1 955
5	229	69.80	7,302	3 212	Low	233	71.02	7,174	3 254
					High	390	118.87	3,977	1 804

Hydraulic Circuit Pressure Settings

Function	Pressure
Winch	3500 PSI 24 132 kPa
Outriggers	2500 PSI 17 237 kPa
Boom Hoist	3000 PSI 20 684 kPa
Telescope	2500 PSI 17 237 kPa
Swing	1900 PSI 13 100 kPa
Steering	2500 PSI 17 237 kPa
Hydraulic Controllers	500 PSI 3 447 kPa

RTC-8030 Lifting Capacities

Refer to Operating Instructions page 12

28.75' - 91' (8.76m - 27.74m) 4-section boom - Intermediate (half extended) Outriggers

Intermediate outriggers																	
28.75' to 70.25' (8.76m - 21.41m) Main Boom with Manual Retracted																	
LOAD RADIUS (ft./m)	28.75' (8.76m)		35' (10.67m)		40' (12.19m)		46' (14.02m)		52' (15.85m)		58' (17.68m)		64' (19.51m)		70.25' (21.41m)		LOAD RADIUS (ft./m)
	LOADED BOOM ANGLE (deg.)	360° (lbs./kgs)	LOADED BOOM ANGLE (deg.)	360° (lbs./kgs)	LOADED BOOM ANGLE (deg.)	360° (lbs./kgs)	LOADED BOOM ANGLE (deg.)	360° (lbs./kgs)	LOADED BOOM ANGLE (deg.)	360° (lbs./kgs)	LOADED BOOM ANGLE (deg.)	360° (lbs./kgs)	LOADED BOOM ANGLE (deg.)	360° (lbs./kgs)	LOADED BOOM ANGLE (deg.)	360° (lbs./kgs)	
10 3.05	66.0	60,000 27 216	70.5	48,600 22 045	73.5	47,800 21 682	76.0	47,200 21 410	78.0	46,800 21 228							10 3.05
12 3.66	61.5	54,000 24 494	67.0	48,600 22 045	70.5	47,800 21 682	73.5	47,200 21 410	76.0	43,800 19 868	77.5	40,200 18 235					12 3.66
15 4.57	54.5	37,100 16 829	61.5	37,100 16 829	65.5	37,100 16 829	69.5	37,100 16 829	72.5	37,100 16 829	74.5	34,900 15 831	76.5	32,100 14 561	78.0	28,500 12 928	15 4.57
20 6.10	40.5	21,100 9 571	51.5	21,100 9 571	57.5	21,100 9 571	62.5	21,100 9 571	66.0	21,100 9 571	69.0	21,100 9 571	71.5	21,100 9 571	74.0	21,100 9 571	20 6.10
25 7.62	20.5	13,900 6 305	40.0	13,900 6 305	48.0	13,900 6 305	55.0	13,900 6 305	59.5	13,900 6 305	63.5	13,900 6 305	66.5	13,900 6 305	69.0	13,900 6 305	25 7.62
30 9.14			24.5	9,900 4 491	37.5	9,900 4 491	46.5	9,900 4 491	53.0	9,900 4 491	57.5	9,900 4 491	61.5	9,900 4 491	64.5	9,900 4 491	30 9.14
35 10.67					22.5	7,400 3 357	37.0	7,400 3 357	45.5	7,400 3 357	51.5	7,400 3 357	56.0	7,400 3 357	59.5	7,400 3 357	35 10.67
40 12.19							24.5	5,700 2 586	37.0	5,700 2 586	44.5	5,700 2 586	50.0	5,700 2 586	54.5	5,700 2 586	40 12.19
45 13.72									26.0	4,400 1 996	36.5	4,400 1 996	44.0	4,400 1 996	49.5	4,400 1 996	45 13.72
50 15.24											27.0	3,400 1 542	36.5	3,400 1 542	43.5	3,400 1 542	50 15.24
55 16.76													28.0	2,600 1 179	37.0	2,600 1 179	55 16.76
60 18.29													15.0	1,900 862	29.0	1,900 862	60 18.29
65 19.81															18.5	1,400 635	65 19.81
0° Angle Capacity		6,900 3 130		4,600 2 087		3,500 1 588		2,500 1 134		1,800 816		1,300 590		900 408			Minimum boom angle degree for no load: 18.5°

Intermediate Outriggers						
LOAD RADIUS (ft./m)	Manual Extended	25' (7.62m) Fly Manual Retracted	25' (7.62m) Fly Manual Extended	LOAD RADIUS (ft./m)		
	91' (27.74m)	95.25' (29.03m)	116' (35.36m)			
	LOADED BOOM ANGLE (deg.)	360° (lbs./kgs)	LOADED BOOM ANGLE (deg.)			360° (lbs./kgs)
20 6.10	79.0	18,600 8 437	78.5	18,200 7 348	20 6.10	
25 7.62	75.5	15,000 6 804	75.5	13,900 6 305	25 7.62	
30 9.14	72.0	10,900 4 944	72.5	11,000 4 990	30 9.14	
35 10.67	68.5	8,400 3 810	69.0	8,500 3 856	35 10.67	
40 12.19	64.5	6,500 2 948	65.5	6,600 2 994	40 12.19	
45 13.72	61.0	5,200 2 359	62.0	5,300 2 404	45 13.72	
50 15.24	57.0	4,200 1 905	58.0	4,300 1 950	50 15.24	
55 16.76	53.0	3,400 1 542	54.5	3,500 1 588	55 16.76	
60 18.29	49.0	2,700 1 225	50.5	2,800 1 270	60 18.29	
65 19.81	44.5	2,100 953	46.0	2,200 998	65 19.81	
70 21.34	39.5	1,700 771	41.5	1,800 816	70 21.34	
75 22.86	34.0	1,300 590	37.0	1,400 635	75 22.86	
80 24.38			31.0	1,100 499	80 24.38	
85 25.91				43.5	1,100 499	85 25.91
	See note A this page.	See note B this page.	See note C this page.			

NOTE A: Minimum boom angle for no load: 34°
 NOTE B: Warning: do not lower 25' fixed fly in working position below 31° unless main boom length is 59' or less, since loss of stability will occur causing a tipping condition.
 NOTE C: Warning: do not lower 25' fixed fly in working position below 43° unless main boom length is 69' or less, since loss of stability will occur causing a tipping condition.
 Minimum boom angle for no load: 34°

RTC-8030 Lifting Capacities

Refer to Operating Instructions page 12

28.75' - 91' (8.76m - 27.74m) 4-section boom - Intermediate (half extended) Outriggers

Intermediate Outriggers													
LOAD RADIUS (ft./m)	25' (7.62m) Fly - Manual Retracted						25' (7.62m) Fly - Manual Extended						LOAD RADIUS (ft./m)
	2° OFFSET		15° OFFSET		30° OFFSET		2° OFFSET		15° OFFSET		30° OFFSET		
	LOADED BOOM ANGLE (deg.)	LOAD (lbs./kgs)	LOADED BOOM ANGLE (deg.)	LOAD (lbs./kgs)	LOADED BOOM ANGLE (deg.)	LOAD (lbs./kgs)	LOADED BOOM ANGLE (deg.)	LOAD (lbs./kgs)	LOADED BOOM ANGLE (deg.)	LOAD (lbs./kgs)	LOADED BOOM ANGLE (deg.)	LOAD (lbs./kgs)	
20 6.10	78.5 5 897	13,000											20 6.10
25 7.62	75.5 5 398	11,900	79.0 4 128	9,100			79.5 4 672	10,300					25 7.62
30 9.14	72.5 4 899	10,800	76.0 3 856	8,500	79.0 2 903	6,400	77.0 4 128	9,100	80.0 3 810	8,400			30 9.14
35 10.67	69.0 3 765	8,300	73.0 3 538	7,800	76.0 2 722	6,000	75.0 3 674	8,100	77.5 3 357	7,400	80.0 2 903	6,400	35 10.67
40 12.19	65.5 2 903	6,400	69.5 3 130	6,900	72.5 2 586	5,700	72.5 3 084	6,800	75.0 2 994	6,800	77.5 2 676	5,900	40 12.19
45 13.72	62.0 2 313	5,100	66.0 2 495	5,500	69.5 2 449	5,400	70.0 2 449	5,400	72.5 2 631	5,800	75.0 2 404	5,300	45 13.72
50 15.24	58.5 1 814	4,000	62.0 1 996	4,400	65.5 2 132	4,700	67.0 1 996	4,400	70.0 2 132	4,700	72.5 2 223	4,900	50 15.24
55 16.76	55.0 1 452	3,200	58.5 1 588	3,500	61.5 1 724	3,800	64.0 1 588	3,500	67.0 1 724	3,800	69.5 1 860	4,100	55 16.76
60 18.29	51.0 1 134	2,500	54.5 1 270	2,800	57.5 1 361	3,000	61.0 1 315	2,900	64.0 1 406	3,100	66.5 1 542	3,400	60 18.29
65 19.81	47.0 907	2,000	50.0 998	2,200	53.0 1 089	2,400	58.0 1 043	2,300	61.0 1 134	2,500	63.5 1 270	2,800	65 19.81
70 21.34	42.5 680	1,500	45.5 771	1,700	48.0 862	1,900	54.5 816	1,800	57.5 907	2,000	60.5 998	2,200	70 21.34
75 22.86	37.5 499	1,100	40.5 590	1,300	43.0 635	1,400	51.5 635	1,400	54.5 726	1,600	57.0 816	1,800	75 22.86
80 24.38					37.0 454	1,000	48.0 499	1,100	50.5 544	1,200	53.0 635	1,400	80 24.38
85 25.91							44.0 363	800	47.0 408	900	49.0 454	1,000	85 25.91

Warning: do not lower 25' offset fly in working position below 37° unless main boom length is 55' or less, since loss of stability will occur causing a tipping condition.

Warning: do not lower 25' offset fly in working position below 47° unless main boom length is 65' or less, since loss of stability will occur causing a tipping condition.

Intermediate Outriggers													
25'- 43' (7.62m - 13.11m) Offset Telescoping Fly + 70.25' (21.41m) Main Boom with Manual Retracted													
LOAD RADIUS (ft./m)	25' (7.62m) Fly						43' (13.11m) Fly						LOAD RADIUS (ft./m)
	2° OFFSET		15° OFFSET		30° OFFSET		2° OFFSET		15° OFFSET		30° OFFSET		
	LOADED BOOM ANGLE (deg.)	LOAD (lbs./kgs)	LOADED BOOM ANGLE (deg.)	LOAD (lbs./kgs)	LOADED BOOM ANGLE (deg.)	LOAD (lbs./kgs)	LOADED BOOM ANGLE (deg.)	LOAD (lbs./kgs)	LOADED BOOM ANGLE (deg.)	LOAD (lbs./kgs)	LOADED BOOM ANGLE (deg.)	LOAD (lbs./kgs)	
20 6.10	78.5 5 761	12,700											20 6.10
25 7.62	75.5 5 216	11,500	79.0 3 992	8,800			77.5 2 223	4,900					25 7.62
30 9.14	72.5 4 763	10,500	76.0 3 720	8,200	79.0 2 767	6,100	75.5 2 132	4,700					30 9.14
35 10.67	69.0 3 629	8,000	73.0 3 402	7,500	76.0 2 586	5,700	73.0 2 041	4,500	78.0 1 814	4,000			35 10.67
40 12.19	65.5 2 767	6,100	69.5 2 994	6,600	72.5 2 449	5,400	70.0 1 950	4,300	75.5 1 769	3,900			40 12.19
45 13.72	62.5 2 177	4,800	66.0 2 359	5,200	69.0 2 313	5,100	67.5 1 860	4,100	72.5 1 678	3,700	77.5 1 361	3,000	45 13.72
50 15.24	58.5 1 678	3,700	62.0 1 860	4,100	65.5 2 041	4,500	65.0 1 769	3,900	70.0 1 588	3,500	74.5 1 315	2,900	50 15.24
55 16.76	55.0 1 315	2,900	58.5 1 452	3,200	61.5 1 588	3,500	62.0 1 633	3,600	67.0 1 497	3,300	71.5 1 225	2,700	55 16.76
60 18.29	51.0 998	2,200	54.5 1 134	2,500	57.5 1 225	2,700	59.0 1 315	2,900	64.0 1 406	3,100	68.5 1 179	2,600	60 18.29
65 19.81	47.0 771	1,700	50.0 862	1,900	53.0 953	2,100	56.0 1 089	2,400	61.0 1 270	2,800	65.5 1 134	2,500	65 19.81
70 21.34	42.5 544	1,200	45.5 635	1,400	48.0 726	1,600	52.5 862	1,900	57.5 998	2,200	62.5 1 089	2,400	70 21.34
75 22.86			40.5 454	1,000	43.0 499	1,100	49.5 680	1,500	54.0 816	1,800	58.5 953	2,100	75 22.86
80 24.38							45.5 499	1,100	50.5 635	1,400	55.0 726	1,600	80 24.38
85 25.91									46.5 499	1,100	50.5 590	1,300	85 25.91
90 27.43											46.0 408	900	90 27.43

Warning: do not lower 25' offset fly in working position below 40° unless main boom length is 51' or less, since loss of stability will occur causing a tipping condition.

Warning: do not lower 43' offset fly in working position below 45° unless main boom length is 48' or less, since loss of stability will occur causing a tipping condition.

RTC-8030 Lifting Capacities

Refer to Operating Instructions page 1:

28.75' - 91' (8.76m - 27.74m) 4-section boom - Intermediate (half extended) Outriggers

Intermediate Outriggers													
25' - 43' (7.62m - 13.11m) Offset Telescoping Fly + 91' (27.74m) Main Boom													
LOAD RADIUS (ft./m)	25' (7.62m) Fly						43' (13.11m) Fly						LOAD RADIUS (ft./m)
	2° OFFSET		15° OFFSET		30° OFFSET		2° OFFSET		15° OFFSET		30° OFFSET		
	LOADED BOOM ANGLE (deg.)	LOAD (lbs./kgs)	LOADED BOOM ANGLE (deg.)	LOAD (lbs./kgs)	LOADED BOOM ANGLE (deg.)	LOAD (lbs./kgs)	LOADED BOOM ANGLE (deg.)	LOAD (lbs./kgs)	LOADED BOOM ANGLE (deg.)	LOAD (lbs./kgs)	LOADED BOOM ANGLE (deg.)	LOAD (lbs./kgs)	
25 7.62	79.5	9,900 4 491										25 7.62	
30 9.14	77.0	8,700 3 946	80.0	8,000 3 629								30 9.14	
35 10.67	75.0	7,700 3 493	77.5	7,000 3 175	80.0	6,000 2 722	78.0	4,900 2 223				35 10.67	
40 12.19	72.5	6,500 2 948	75.0	6,200 2 812	77.5	5,500 2 495	75.5	4,700 2 132	79.0	4,000 1 814		40 12.19	
45 13.72	70.0	5,100 2 313	72.5	5,500 2 495	75.0	5,000 2 268	73.5	4,500 2 041	77.5	3,900 1 769		45 13.72	
50 15.24	67.0	4,000 1 814	70.0	4,400 1 996	72.5	4,500 2 041	71.5	4,300 1 950	75.5	3,700 1 678	79.0	3,100 1 406	50 15.24
55 16.76	64.0	3,200 1 452	67.0	3,500 1 588	69.5	3,800 1 724	69.0	3,800 1 724	73.0	3,400 1 542	77.0	3,000 1 361	55 16.76
60 18.29	61.0	2,500 1 134	64.0	2,800 1 270	66.5	3,100 1 406	66.5	3,100 1 406	70.5	3,100 1 406	74.5	2,800 1 270	60 18.29
65 19.81	58.0	2,000 907	61.0	2,200 998	63.5	2,500 1 134	64.5	2,500 1 134	68.0	2,800 1 270	72.0	2,600 1 179	65 19.81
70 21.34	54.5	1,500 680	57.5	1,700 771	60.5	1,900 862	61.5	2,000 907	65.5	2,400 1 089	69.5	2,400 1 089	70 21.34
75 22.86	51.5	1,100 499	54.5	1,300 590	57.0	1,500 680	59.0	1,600 726	63.0	2,000 907	66.5	2,200 998	75 22.86
80 24.38			50.5	900 408	53.0	1,100 499	56.0	1,300 590	60.5	1,600 726	64.0	1,900 862	80 24.38
85 25.91							53.5	1,000 454	58.0	1,200 544	61.0	1,500 680	85 25.91
90 27.43									54.5	900 408	58.0	1,200 544	90 27.43
95 28.96										54.5	900 408	95 28.96	

Warning: do not lower 25' offset fly in working position below 50° unless main boom length is 60' or less, since loss of stability will occur causing a tipping condition.
Warning: do not lower 43' offset fly in working position below 52° unless main boom length is 57' or less, since loss of stability will occur causing a tipping condition.

28.75' - 91' (8.76m - 27.74m) 4-section boom - Outriggers Fully Retracted

Outriggers Fully Retracted																			
28.75' - 70.25' (8.76m - 21.41m) Main Boom with Manual Retracted											Manual Extended								
LOAD RADIUS (ft./m)	28.75' (8.76m)		35' (10.67m)		40' (12.19m)		46' (14.02m)		52' (15.85m)		58' (17.68m)		64' (19.51m)		70.25' (21.41m)		91' (27.74m)		LOAD RADIUS (ft./m)
	LOADED BOOM ANGLE (deg.)	360° (lbs./kgs)	LOADED BOOM ANGLE (deg.)	360° (lbs./kgs)	LOADED BOOM ANGLE (deg.)	360° (lbs./kgs)	LOADED BOOM ANGLE (deg.)	360° (lbs./kgs)	LOADED BOOM ANGLE (deg.)	360° (lbs./kgs)	LOADED BOOM ANGLE (deg.)	360° (lbs./kgs)	LOADED BOOM ANGLE (deg.)	360° (lbs./kgs)	LOADED BOOM ANGLE (deg.)	360° (lbs./kgs)	LOADED BOOM ANGLE (deg.)	360° (lbs./kgs)	
10 3.05	66.0	34,100 15 468	70.5	34,100 15 468	73.0	34,100 15 468	75.5	34,000 15 422	77.5	34,000 15 422									10 3.05
12 3.66	61.5	24,300 11 022	67.0	24,300 11 022	70.0	24,300 11 022	73.0	24,300 11 022	75.5	24,300 11 022	77.0	24,300 11 022							12 3.66
15 4.57	54.0	16,400 7 439	61.5	16,400 7 439	65.5	16,400 7 439	69.0	16,400 7 439	71.5	16,400 7 439	74.0	16,400 7 439	75.5	16,400 7 439	77.5	16,400 7 439			15 4.57
20 6.10	40.5	9,800 4 445	51.5	9,800 4 445	57.0	9,800 4 445	62.0	9,800 4 445	65.5	9,800 4 445	68.5	9,800 4 445	71.0	9,800 4 445	73.0	9,800 4 445	78.0	10,700 4 854	20 6.10
25 7.62	20.5	6,400 2 903	40.0	6,400 2 903	48.0	6,400 2 903	54.5	6,400 2 903	59.5	6,400 2 903	63.0	6,400 2 903	66.0	6,400 2 903	68.5	6,400 2 903	74.5	7,300 3 311	25 7.62
30 9.14			24.0	4,300 1 950	37.5	4,300 1 950	46.5	4,300 1 950	52.5	4,300 1 950	57.0	4,300 1 950	61.0	4,300 1 950	64.0	4,300 1 950	71.0	5,200 2 359	30 9.14
35 10.67					22.5	2,900 1 315	37.0	2,900 1 315	45.0	2,900 1 315	51.0	2,900 1 315	55.5	2,900 1 315	59.0	2,900 1 315	67.5	3,800 1 724	35 10.67
40 12.19							24.5	2,000 907	36.5	2,000 907	44.0	2,000 907	49.5	2,000 907	54.0	2,000 907	64.0	2,800 1 270	40 12.19
45 13.72									26.0	1,200 544	36.5	1,200 544	43.5	1,200 544	49.0	1,200 544	60.5	2,000 907	45 13.72
50 15.24																	56.5	1,400 635	50 15.24
0° angle capacity		3,200 1 452	1,900 862	1,200 544	17.0	0	26.0	0	36.0	0	43.5	0	49.0	0	56.0	0	Minimum boom angle for no load		

RTC-8030 Lifting Capacities

Refer to Operating Instructions page 12

28.75' - 91' (8.76m - 27.74m) 4-section boom - On Rubber Capacities

On Rubber Capacities with 20.5 x 25 Tires																
Tire Pressure (0-1 mph) : 80 psi																
Pick & Carry Capacities - creep - Boom Centered over Front																
4-Section Boom																
LOAD RADIUS (ft./m)	Main Boom Length															
	28.75' (8.76m)		35' (10.67m)		40' (12.19m)		46' (14.02m)		52' (15.85m)		58' (17.68m)		64' (19.51m)		70.25' (21.41m)	
	LOADED BOOM ANGLE (deg.)	OVER FRONT (lbs./kgs)	LOADED BOOM ANGLE (deg.)	OVER FRONT (lbs./kgs)	LOADED BOOM ANGLE (deg.)	OVER FRONT (lbs./kgs)	LOADED BOOM ANGLE (deg.)	OVER FRONT (lbs./kgs)	LOADED BOOM ANGLE (deg.)	OVER FRONT (lbs./kgs)	LOADED BOOM ANGLE (deg.)	OVER FRONT (lbs./kgs)	LOADED BOOM ANGLE (deg.)	OVER FRONT (lbs./kgs)	LOAD RADIUS (ft./m)	
10	66.0	34,800	70.5	34,700											10	
3.05		15 785		15 740											3.05	
12	61.5	30,000	67.0	30,000	70.5	29,900									12	
3.66		13 608		13 608		13 563									3.66	
15	54.5	24,700	61.5	24,700	66.0	24,700	69.5	24,600							15	
4.57		11 204		11 204		11 204		11 159							4.57	
20	40.5	18,600	52.0	18,600	57.5	18,600	62.5	18,600	66.5	18,600	69.5	18,600			20	
6.10		8 437		8 437		8 437		8 437		8 437		8 437			6.10	
25	20.5	14,400	40.0	14,400	48.5	14,400	55.0	14,400	60.0	14,400	64.0	14,400	67.0	14,400	25	
7.62		6 532		6 532		6 532		6 532		6 532		6 532		6 532	7.62	
30			24.5	11,200	37.5	11,200	47.0	11,200	53.5	11,200	58.0	11,200	62.0	11,200	65.5	11,200
9.14				5 080		5 080		5 080		5 080		5 080		5 080	9.14	
35					23.0	8,400	37.5	8,400	46.0	8,400	52.0	8,400	56.5	8,400	60.5	8,400
10.67						3 810		3 810		3 810		3 810		3 810	10.67	
40							25.0	6,500	37.5	6,500	45.0	6,500	51.0	6,500	55.5	6,500
12.19								2 948		2 948		2 948		2 948	12.19	
45									26.5	5,100	37.5	5,100	44.5	5,100	50.0	5,100
13.72										2 313		2 313		2 313	13.72	
50											27.5	4,000	37.5	4,000	44.5	4,000
15.24												1 814		1 814	15.24	
55													28.5	3,100	37.5	3,100
16.76														1 406	16.76	
60													16.0	2,400	30.0	2,400
18.29														1 089	18.29	
65															19.5	1,800
19.81															19.81	

Minimum boom angle for no load: 0°

On Rubber Capacities with 20.5 x 25 Tires																
Tire Pressure: 80 psi																
Stationary Capacities - 360°																
4-Section Boom																
LOAD RADIUS (ft./m)	Main Boom Length															
	28.75' (8.76m)		35' (10.67m)		40' (12.19m)		46' (14.02m)		52' (15.85m)		58' (17.68m)		64' (19.51m)		70.25' (21.41m)	
	LOADED BOOM ANGLE (deg.)	360° (lbs./kgs)	LOADED BOOM ANGLE (deg.)	360° (lbs./kgs)	LOADED BOOM ANGLE (deg.)	360° (lbs./kgs)	LOADED BOOM ANGLE (deg.)	360° (lbs./kgs)	LOADED BOOM ANGLE (deg.)	360° (lbs./kgs)	LOADED BOOM ANGLE (deg.)	360° (lbs./kgs)	LOADED BOOM ANGLE (deg.)	360° (lbs./kgs)	LOAD RADIUS (ft./m)	
10	66.0	19,000	70.5	19,000	73.5	18,900									10	
3.05		8 618		8 618		8 573									3.05	
12	61.5	15,800	67.0	15,800	70.5	15,800	73.5	15,800							12	
3.66		7 167		7 167		7 167		7 167							3.66	
15	54.5	12,300	61.5	12,300	66.0	12,300	69.5	12,300	72.5	12,300					15	
4.57		5 579		5 579		5 579		5 579		5 579					4.57	
20	40.5	8,400	52.0	8,400	57.5	8,400	62.5	8,400	66.5	8,400	69.5	8,400			20	
6.10		3 810		3 810		3 810		3 810		3 810		3 810			6.10	
25	20.5	5,400	40.0	5,400	48.5	5,400	55.0	5,400	60.0	5,400	64.0	5,400	67.0	5,400	70.0	5,400
7.62		2 449		2 449		2 449		2 449		2 449		2 449		2 449	7.62	
30			24.5	3,600	37.5	3,600	47.0	3,600	53.5	3,600	58.0	3,600	62.0	3,600	65.5	3,600
9.14				1 633		1 633		1 633		1 633		1 633		1 633	9.14	
35					23.0	2,300	37.5	2,300	46.0	2,300	52.0	2,300	56.5	2,300	60.5	2,300
10.67						1 043		1 043		1 043		1 043		1 043	10.67	
40							25.0	1,400	37.5	1,400	45.0	1,400	51.0	1,400	55.5	1,400
12.19								635		635		635		635	12.19	
Min. Boom angle for no load	0		0		0		25.0		37.0		45.0		50.0		55.0	

RTC-8030 Lifting Capacities

Refer to Operating Instructions page 12

28.75' - 91' (8.76m - 27.74m) 4-section boom - On Rubber Capacities

On Rubber Capacities with 20.5 x 25 Tires																	
Tire Pressure (0-1 mph) : 80 psi																	
Stationary Capacities - Between Tracks Over Front																	
4-Section Boom																	
LOAD RADIUS (ft./m)	Main Boom Length																
	28.75' (8.76m)		35' (10.67m)		40' (12.19m)		46' (14.02m)		52' (15.85m)		58' (17.68m)		64' (19.51m)		70.25' (21.41m)		
	LOADED BOOM ANGLE (deg.)	OVER FRONT (lbs./kgs)	LOADED BOOM ANGLE (deg.)	OVER FRONT (lbs./kgs)	LOADED BOOM ANGLE (deg.)	OVER FRONT (lbs./kgs)	LOADED BOOM ANGLE (deg.)	OVER FRONT (lbs./kgs)	LOADED BOOM ANGLE (deg.)	OVER FRONT (lbs./kgs)	LOADED BOOM ANGLE (deg.)	OVER FRONT (lbs./kgs)	LOADED BOOM ANGLE (deg.)	OVER FRONT (lbs./kgs)	LOADED BOOM ANGLE (deg.)	OVER FRONT (lbs./kgs)	
10	66.0	35,900	70.5	35,900	73.5	35,800										10	
3.05		16 284		16 284		16 239										3.05	
12	61.5	31,600	67.0	31,500	70.5	31,500	73.5	31,400								12	
3.66		14 334		14 289		14 289		14 243								3.66	
15	54.5	26,600	61.5	26,500	66.0	26,500	69.5	26,500	72.5	26,500						15	
4.57		12 066		12 020		12 020		12 020		12 020						4.57	
20	40.5	20,500	52.0	20,500	57.5	20,500	62.5	20,500	66.5	20,500	69.5	20,500				20	
6.10		9 299		9 299		9 299		9 299		9 299		9 299				6.10	
25	20.5	15,600	40.0	15,600	48.5	15,600	55.0	15,600	60.0	15,600	64.0	15,600	70.0	15,600		25	
7.62		7 076		7 076		7 076		7 076		7 076		7 076		7 076		7.62	
30			24.5	11,200	37.5	11,200	47.0	11,200	53.5	11,200	58.0	11,200	62.0	11,200	65.5	11,200	30
9.14				5 080		5 080		5 080		5 080		5 080		5 080		5 080	9.14
35					23.0	8,400	37.5	8,400	46.0	8,400	52.0	8,400	56.5	8,400	60.5	8,400	35
10.67						3 810		3 810		3 810		3 810		3 810		3 810	10.67
40							25.0	6,500	37.5	6,500	45.0	6,500	51.0	6,500	55.5	6,500	40
12.19								2 948		2 948		2 948		2 948		2 948	12.19
45									26.5	5,100	37.5	5,100	44.5	5,100	50.0	5,100	45
13.72										2 313		2 313		2 313		2 313	13.72
50											27.5	4,000	37.5	4,000	44.5	4,000	50
15.24												1 814		1 814		1 814	15.24
55													28.5	3,100	37.5	3,100	55
16.76														1 406		1 406	16.76
60													16.0	2,400	30.0	2,400	60
18.29														1 089		1 089	18.29
65															19.5	1,800	65
19.81																816	19.81

Minimum boom angle for no load: 0°

On Rubber Capacities with 23.5 x 25 Tires																	
Tire Pressure (0-1 mph) : 70 psi																	
Pick & Carry Capacities - Creep - Boom Centered Over Front																	
4-Section Boom																	
LOAD RADIUS (ft./m)	Main Boom Length																
	28.75' (8.76m)		35' (10.67m)		40' (12.19m)		46' (14.02m)		52' (15.85m)		58' (17.68m)		64' (19.51m)		70.25' (21.41m)		
	LOADED BOOM ANGLE (deg.)	OVER FRONT (lbs./kgs)	LOADED BOOM ANGLE (deg.)	OVER FRONT (lbs./kgs)	LOADED BOOM ANGLE (deg.)	OVER FRONT (lbs./kgs)	LOADED BOOM ANGLE (deg.)	OVER FRONT (lbs./kgs)	LOADED BOOM ANGLE (deg.)	OVER FRONT (lbs./kgs)	LOADED BOOM ANGLE (deg.)	OVER FRONT (lbs./kgs)	LOADED BOOM ANGLE (deg.)	OVER FRONT (lbs./kgs)	LOADED BOOM ANGLE (deg.)	OVER FRONT (lbs./kgs)	
10	66.0	43,500														10	
3.05		19 732														3.05	
12	61.5	37,800	67.0	37,700												12	
3.66		17 146		17 101												3.66	
15	54.5	31,300	61.5	31,300	66.0	31,200										15	
4.57		14 198		14 198		14 152										4.57	
20	40.5	23,800	52.0	23,800	57.5	23,800	62.5	23,800								20	
6.10		10 796		10 796		10 796		10 796								6.10	
25	20.5	15,700	40.0	15,700	48.5	15,700	55.0	15,700	60.0	15,700	64.0	15,700				25	
7.62		7 122		7 122		7 122		7 122		7 122		7 167				7.62	
30			24.5	11,300	37.5	11,300	47.0	11,300	53.5	11,300	58.0	11,300	62.0	11,300	65.5	11,300	30
9.14				5 126		5 126		5 126		5 126		5 126		5 126		5 126	9.14
35					23.0	8,500	37.5	8,500	46.0	8,500	52.0	8,500	56.5	8,500	60.5	8,500	35
10.67						3 856		3 856		3 856		3 856		3 856		3 856	10.67
40							25.0	6,500	37.5	6,500	45.0	6,500	51.0	6,500	55.5	6,500	40
12.19								2 948		2 948		2 948		2 948		2 948	12.19
45									26.5	5,100	37.5	5,100	44.5	5,100	50.0	5,100	45
13.72										2 313		2 313		2 313		2 313	13.72
50											27.5	4,000	37.5	4,000	44.5	4,000	50
15.24												1 814		1 814		1 814	15.24
55													28.5	3,100	37.5	3,100	55
16.76														1 406		1 406	16.76
60													16.0	2,400	30.0	2,400	60
18.29														1 089		1 089	18.29
65															19.5	1,800	65
19.81																816	19.81

Minimum boom angle for no load: 0°

RTC-8030 Lifting Capacities

Refer to Operating Instructions page 12

28.75' - 91' (8.76m - 27.74m) 4-section boom - On Rubber Capacities

On Rubber Capacities with 23.5 x 25 Tires

Tire Pressure: 70 psi
Stationary Capacities - 360°
4-Section Boom

LOAD RADIUS (ft./m)	Main Boom Length														LOAD RADIUS (ft./m)		
	28.75' (8.76m)		35' (10.67m)		40' (12.19m)		46' (14.02m)		52' (15.85m)		58' (17.68m)		64' (19.51m)			70.25' (21.41m)	
	LOADED BOOM ANGLE (deg.)	360° (lbs./kgs)	LOADED BOOM ANGLE (deg.)	360° (lbs./kgs)	LOADED BOOM ANGLE (deg.)	360° (lbs./kgs)	LOADED BOOM ANGLE (deg.)	360° (lbs./kgs)	LOADED BOOM ANGLE (deg.)	360° (lbs./kgs)	LOADED BOOM ANGLE (deg.)	360° (lbs./kgs)	LOADED BOOM ANGLE (deg.)	360° (lbs./kgs)		LOADED BOOM ANGLE (deg.)	360° (lbs./kgs)
10 3.05	66.0	24,900 11 295	70.5	24,800 11 249	73.5	24,800 11 249											10 3.05
12 3.66	61.5	20,900 9 480	67.0	20,900 9 480	70.5	20,900 9 480	73.5	20,800 9 435									12 3.66
15 4.57	54.5	14,200 6 441	61.5	14,200 6 441	66.0	14,200 6 441	69.5	14,200 6 441	72.5	14,200 6 441							15 4.57
20 6.10	40.5	8,500 3 856	52.0	8,500 3 856	57.5	8,500 3 856	62.5	8,500 3 856	66.5	8,500 3 856	69.5	8,500 3 856					20 6.10
25 7.62	20.5	5,400 2 449	40.0	5,400 2 449	48.5	5,400 2 449	55.0	5,400 2 449	60.0	5,400 2 449	64.0	5,400 2 449	67.0	5,400 2 449	70.0	5,400 2 449	25 7.62
30 9.14			24.5	3,600 1 633	37.5	3,600 1 633	47.0	3,600 1 633	53.5	3,600 1 633	58.0	3,600 1 633	62.0	3,600 1 633	65.5	3,600 1 633	30 9.14
35 10.67					23.0	2,300 1 043	37.5	2,300 1 043	46.0	2,300 1 043	52.0	2,300 1 043	56.5	2,300 1 043	60.5	2,300 1 043	35 10.67
40 12.19							25.0	1,500 680	37.5	1,500 680	45.0	1,500 680	51.0	1,500 680	55.5	1,500 680	40 12.19
Min. Boom angle for no load	0		0		0		25.0		37.0		45.0		51.0		55.0		

On Rubber Capacities with 23.5 x 25 Tires

Tire Pressure (0-1 mph) : 70 psi
Stationary Capacities - Between Tracks Over Front
4-Section Boom

LOAD RADIUS (ft./m)	Main Boom Length														LOAD RADIUS (ft./m)		
	28.75' (8.76m)		35' (10.67m)		40' (12.19m)		46' (14.02m)		52' (15.85m)		58' (17.68m)		64' (19.51m)			70.25' (21.41m)	
	LOADED BOOM ANGLE (deg.)	OVER FRONT (lbs./kgs)	LOADED BOOM ANGLE (deg.)	OVER FRONT (lbs./kgs)	LOADED BOOM ANGLE (deg.)	OVER FRONT (lbs./kgs)	LOADED BOOM ANGLE (deg.)	OVER FRONT (lbs./kgs)	LOADED BOOM ANGLE (deg.)	OVER FRONT (lbs./kgs)	LOADED BOOM ANGLE (deg.)	OVER FRONT (lbs./kgs)	LOADED BOOM ANGLE (deg.)	OVER FRONT (lbs./kgs)		LOADED BOOM ANGLE (deg.)	OVER FRONT (lbs./kgs)
10 3.05	66.0	44,300 20 094	70.5	44,200 20 049	73.5	44,100 20 004											10 3.05
12 3.66	61.5	39,100 17 736	67.0	39,000 17 690	70.5	39,000 17 690	73.5	38,900 17 645									12 3.66
15 4.57	54.5	32,300 14 651	61.5	32,300 14 651	66.0	32,300 14 651	69.5	32,200 14 606	72.5	32,100 14 561							15 4.57
20 6.10	40.5	23,800 10 796	52.0	23,800 10 796	57.5	23,800 10 796	62.5	23,800 10 796	66.5	23,800 10 796	69.5	23,800 10 796					20 6.10
25 7.62	20.5	15,700 7 122	40.0	15,700 7 122	48.5	15,700 7 122	55.0	15,700 7 122	60.0	15,700 7 122	64.0	15,700 7 122	67.0	15,700 7 122	70.0	15,700 7 122	25 7.62
30 9.14			24.5	11,300 5 126	37.5	11,300 5 126	47.0	11,300 5 126	53.5	11,300 5 126	58.0	11,300 5 126	62.0	11,300 5 126	65.5	11,300 5 126	30 9.14
35 10.67					23.0	8,500 3 856	37.5	8,500 3 856	46.0	8,500 3 856	52.0	8,500 3 856	56.5	8,500 3 856	60.5	8,500 3 856	35 10.67
40 12.19							25.0	6,500 2 948	37.5	6,500 2 948	45.0	6,500 2 948	51.0	6,500 2 948	55.5	6,500 2 948	40 12.19
45 13.72									26.5	5,100 2 313	37.5	5,100 2 313	44.5	5,100 2 313	50.0	5,100 2 313	45 13.72
50 15.24											27.5	4,000 1 814	37.5	4,000 1 814	44.5	4,000 1 814	50 15.24
55 16.76													28.5	3,100 1 406	37.5	3,100 1 406	55 16.76
60 18.29													16.0	2,400 1 089	30.0	2,400 1 089	60 18.29
65 19.81															19.5	1,800 816	65 19.81
Minimum boom angle for no load: 0°																	

RTC-8030 4-section boom — Warning and Operating Instructions

GENERAL:

1. Rated lifting capacities in pounds as shown on lift chart pertain to this machine as originally manufactured and normally equipped. Modifications to the machine or use of optional equipment other than that specified can result in a reduction of capacity.
2. Construction equipment can be dangerous if improperly operated or maintained. Operation and maintenance of this machine must be in compliance with the information in the operator's, parts and safety manuals supplied with this machine. If these manuals are missing, order replacements through the distributor.
3. The operator and other personnel associated with this machine shall fully acquaint themselves with the latest applicable American National Standards Institute (ANSI) safety standards for cranes.
4. The maximum allowable lifting capacities are based on machine standing level on firm supporting surface.

SET-UP

1. The machine shall be leveled on a firm supporting surface. Depending on the nature of the supporting surface, it may be necessary to have structural supports under the outrigger floats or tires to spread the load to a larger bearing surface.
2. When making lifts on outriggers, tires must be free of supporting surface. All outrigger beams must be extended to the same length; fully retracted, half extended, or fully extended.
3. When making lifts on tires, they must be inflated to the recommended pressure. (See note 19).
4. For required parts of line, see wire rope strength and winch performance tables.

OPERATION:

1. Rated lifting capacities at rated radius shall not be exceeded. Do not tip the machine to determine allowable loads. For concrete bucket operation, weight of bucket and load shall not exceed 80% of rated lifting capacities. For clamshell bucket operation, weight of bucket and bucket contents is restricted to a maximum weight of 5000 pounds or 80% of rated lifting capacity, whichever is less. For magnet operation, weight of magnet and load is restricted to a maximum weight of 5000 pounds or 80% of rated lifting capacity, whichever is less. For clamshell and magnet operation, maximum boom length is restricted to 46 feet and the boom angle is restricted to a minimum of 38 degrees. Lifts with any fly erected or manual extended are prohibited

for both clam and magnet operation.

2. The crane capacities shown on fully extended outriggers do not exceed 85% of the tipping loads. The crane capacities shown on half extended outriggers, fully retracted outriggers or tires do not exceed 75% of the tipping loads as determined by SAE crane stability test code J-765A.
3. The shaded crane capacities above the bold lines are based on structural strength or hydraulic limitations.
4. Rated lifting capacities include the weight of hook block, slings, bucket, magnet and auxiliary lifting devices. Their weights must be subtracted from the listed rated load to obtain the net load to be lifted. See also deductions for auxiliary head, fixed fly, offset fly, 25-43 Ft. offset telescoping fly.
5. Rated lifting capacities are based on freely suspended loads. No attempt shall be made to move a load horizontally on the ground in any direction.
6. Rated lifting capacities are for lift crane service only.
7. Do not operate at radii or boom lengths where capacities are not listed. At these positions, the machine can overturn without any load on the hook.
8. The maximum loads which can be telescoped are not definable because of variation in loadings and crane maintenance, but it is permissible to attempt retraction and extension within the limits of the load rating chart.
9. When either boom length or radius or both are between values listed, the smallest load shown at either the next larger radius or boom length shall be used.
10. The user shall operate at reduced ratings to allow for adverse job conditions, such as: soft or uneven ground, out of level conditions, wind, side loads, pendulum action, jerking or sudden stopping of loads, hazardous conditions, experience of personnel, two machine lifts, traveling with loads, electrical wires, etc. Side load on boom or fly is extremely dangerous.
11. When making lifts with auxiliary head machinery, the effective length of the boom increases by 2 feet.
12. Power sections of boom must be extended equally.
13. The least stable rated working area on outriggers is over the rear.
14. Rated lifting capacities are based on correct reeving. Deduction must be made for excessive reeving. Any reeving over minimum required (see wire rope strength table) is considered excessive and must be accounted for. Use

working range diagram to estimate the extra feet of rope the deduct 1 lb. for each foot of wire rope before attempting to lift a load.

15. The loaded boom angle combined with the boom length give only an approximation of the operating radius. The boom angle, before loading, should be greater to account for deflection.
16. For fly capacities with main boom length less than 70.25 ft. (manual retracted) or 91 ft. (manual extended) the rated loads are determined by the boom angle only in the fly capacity columns. For angles not shown use the next lower boom angle to determine the allowable capacity.
17. For boom lengths less than 91 ft. with manual extended, the rated loads are determined by boom angle only in the column headed by 91 ft. For angles not shown, use the next lower boom angle to determine allowable capacity.
18. The 28.75 ft. boom length capacities are based on boom fully retracted. If the boom is not fully retracted, do not exceed capacities shown for the 35 ft. boom length.
19. Crane capacities on tires depend on tire capacity, condition of tires, and tire air pressure. On tire picks require lifting from main boom head only on a smooth and level surface. Pick and carry operations (creep) are restricted to a maximum speed of 1 MPH and not exceeding 200 ft. in a 30 minute period. The boom must be centered over the front of the machine with two position travel swing lock engaged and the load must be restrained from swinging. Lifts with manual extended or any fly erected on tires are prohibited. Tire inflation pressure for stationary and creep operations is 80 PSI for 20.5 x 25 tires and 70 PSI for 23.5 x 25 tires.

DEFINITIONS:

1. Load Radius: Horizontal distance from a projection of the axis of rotation to the supporting surface before loading to the center of the vertical hoist line or tackle with load applied.
2. Loaded Boom Angle: The angle between the boom base section and the horizontal after lifting the load at the rated radius.
3. Working Area: Area measured in a circular arc about the center line of rotation as shown on the working area plate.
4. Freely Suspended Load: Load hanging free with no direct external force applied except by the hoist line.
5. Side Load: Horizontal side force applied to the lifted load either on the ground or in the air.

RTC-8030 Working Areas

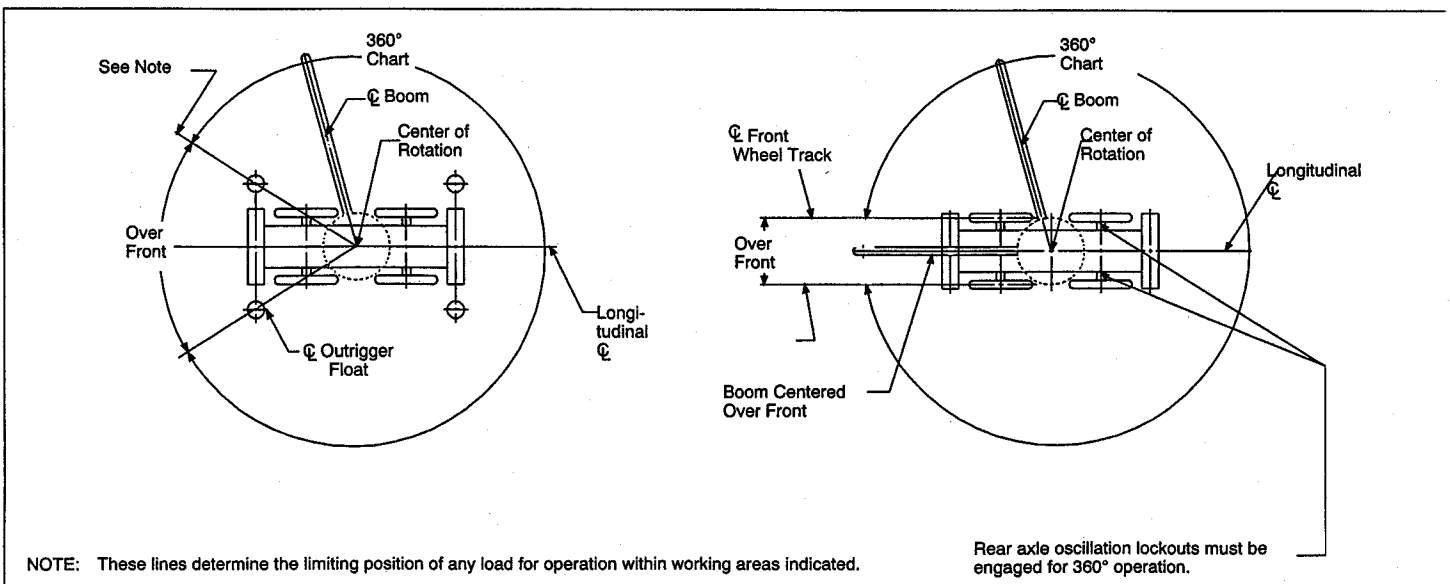

Link-Belt Construction Equipment Company

Lexington, Kentucky

A unit of Sumitomo Construction Machinery Co., Ltd.

©Link-Belt is a registered trademark. All rights reserved. Copyright 1992.

We are constantly improving our products and therefore reserve the right to change designs and specifications.