

GROVE®

RT700E

product guide

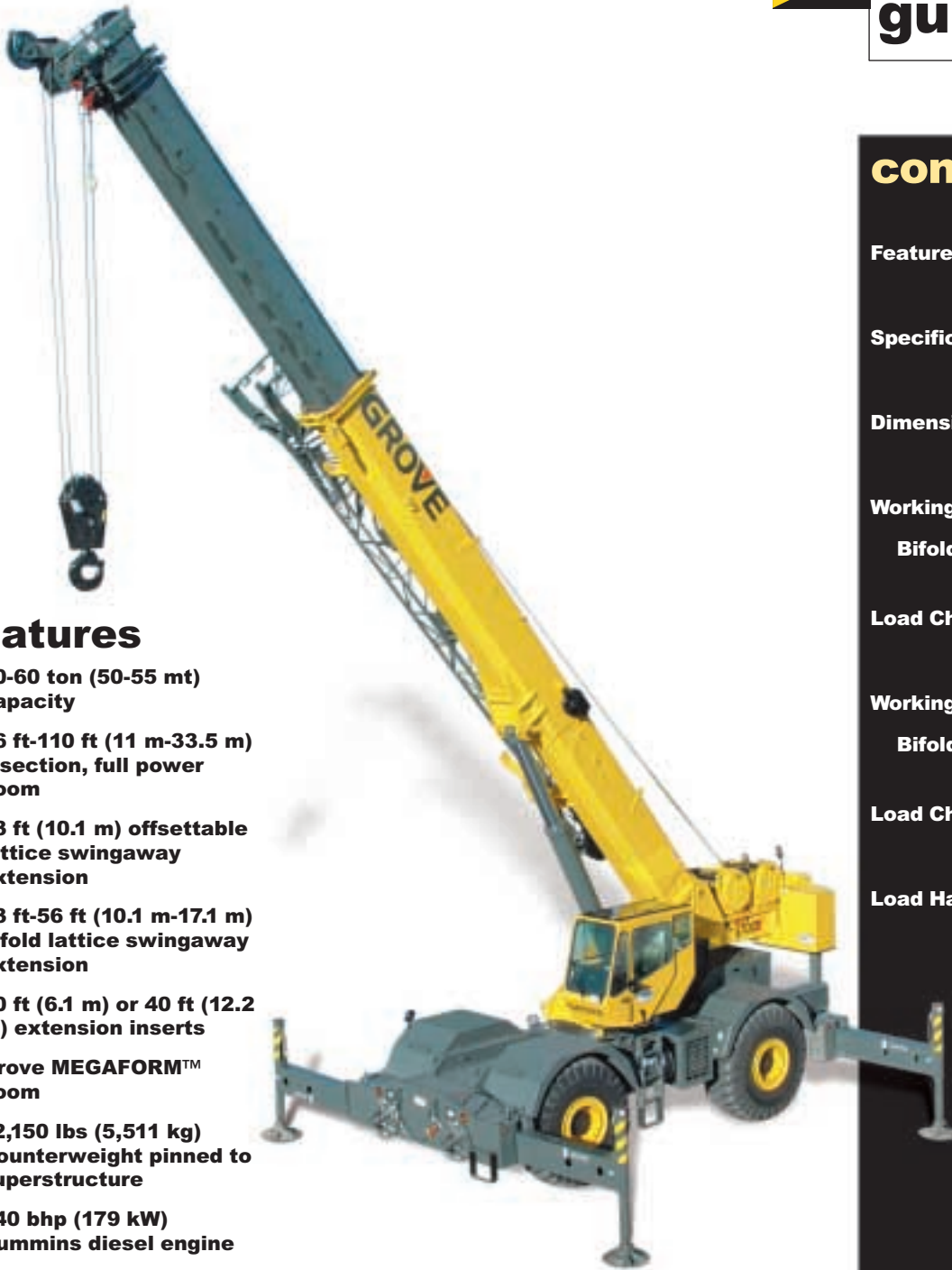

features

- 50-60 ton (50-55 mt) capacity
- 36 ft-110 ft (11 m-33.5 m) 4 section, full power boom
- 33 ft (10.1 m) offsettable lattice swingaway extension
- 33 ft-56 ft (10.1 m-17.1 m) bifold lattice swingaway extension
- 20 ft (6.1 m) or 40 ft (12.2 m) extension inserts
- Grove MEGAFORM™ boom
- 12,150 lbs (5,511 kg) Counterweight pinned to superstructure
- 240 bhp (179 kW) Cummins diesel engine
- Grove "E" series cab

contents

Features	2
Specifications	3
Dimensions	5
Working Range Bifold	6
Load Charts	7
Working Range Bifold & Inserts	10
Load Charts	11
Load Handling	15

Rough Terrain Hydraulic Crane

features

2



The superstructure features a full-power four-section MEGAFORM boom that can reach to a maximum tip height of 119 ft. The sequence synchronized extension feature: telescopes boom sections with a touch of the hand via a single lever joystick controller.



An optional bi-fold swingaway lattice extension easily stows on the side of the base boom for easy transport while providing on-board extension from 33-56 ft. for a maximum tip height of 174.5 ft. By adding inserts of 20 or 40 ft. the max tip height on the RT700E can be extended even further to 194 ft. or 214 ft.



An optional 33 ft. fixed swingaway is also available with a max tip height of 150 ft.



The RT700E has a quick-reeve boom nose and swingaway alignment device to help operators set up smoothly.



The features common to the Grove "E" Series cab include:

- hot water heater/defroster
- single axis joystick controllers
- sliding skylight and adjustable sunscreen
- engine instrumentation
- full acoustical lining



The PAT iFlex 5 graphic display LMI includes a work area definition system which allows the operator to define a preferred working area.



Large open stowage compartment for tools and rigging accessories.



specifications

3

Superstructure

Boom

36 ft. - 110 ft. (11 m - 33.5 m) four-section, full-power sequenced synchronized boom.

Maximum tip height: 119 ft. (36.4 m).

*Optional Fixed Swingaway Extension

33 ft. (10.1 m) offsettable lattice swingaway extension. Offsettable at 0°, 25° and 45°. Stows alongside base boom section. Maximum tip height: 150 ft. (45.8 m).

*Optional Bi-Fold Swingaway Extension

33 ft. - 56 ft. (10.1 m - 17.1 m) bi-fold lattice swingaway extension. Offsettable at 0°, 25° and 45°. Stows alongside base boom section. Maximum tip height: 174.5 ft. (53.2 m).

*Optional 20 ft. (6.1 m) or 40 ft. (12.2 m) Inserts

Installs between boom nose and bi-fold extension, non-stowable. Maximum tip height: 194 ft. (59.1 m)-20 ft. insert, 214 ft. (65.2 m)-40 ft. insert.

Boom Nose

Three nylatron sheaves (four with 60-ton rating) mounted on heavy-duty tapered roller bearings with removable pin-type rope guards. Quick-reeve type boom nose.

*Optional removable auxiliary boom nose with removable pin type rope guard.

Boom Elevation

One double-acting hydraulic cylinder with integral holding valve provides elevation from -3° to 78°.

Load Moment & Anti-Two Block System

Standard "Graphic Display" load moment and anti-two block system with audio-visual warning and control lever lockout. These systems provide electronic display of boom angle, length, radius, tip height, relative load moment, maximum permissible load, load indication and warning of impending two-block condition. The standard Work Area Definition System allows the operator to pre-select and define safe working areas. If the crane approaches the pre-set limits, audio-visual warnings aid the operator in avoiding job-site obstructions.

Cab

Full-vision, all-steel fabricated with acoustical lining and tinted safety glass throughout. Deluxe seat incorporates armrest-mounted hydraulic single-axis controllers. Dash panel incorporates gauges for all engine functions. Other standard features include: hot water heater, cab circulating air fan, sliding side and rear windows, sliding skylight with electric wiper and sunscreen, electric windshield wash/wipe, fire extinguisher and seat belt.

Swing

Planetary swing with foot-applied multi-disc brake. Spring applied, hydraulically-released swing brake and plunger-type, one position, mechanical house lock operated from cab.

*Optional 360° mechanical swing lock. Maximum speed: 2.5 RPM.

Counterweight

12,150 lbs. (5511 kg) pinned to superstructure.

Hydraulic System

Three main gear pumps with a combined capacity of 103 GPM (391 LPM), 135 GPM (511 LPM) with optional air conditioning. Maximum operating pressure: 4000 psi (27.6 MPa). Two individual post pressure compensated valve banks.

Return line type filter with full flow by-pass protection and service indicator. Replaceable cartridge with micron filtration rating of 5/12/16. 132 gallon (500 L) reservoir. Integral oil cooler. System pressure test ports.

Hoist Specifications

Main and Auxiliary Hoist: Grove Model H030G-16G

Planetary reduction with automatic spring applied multi-disc brake. Grooved drum. Electronic hoist drum rotation indicator and hoist drum cable followers.

Maximum Single Line Pull: 18,180 lbs
(8 246 kg)

Maximum Single Line Speed: 588 FPM
(179 m/min)

Maximum Permissible Line Pull:
16,800 lbs. (7 620 kg) w/standard 6 x 37 class rope
16,800 lbs. (7 620 kg) w/optional 35 x 7 class rope

Rope Diameter: 3/4 in. (19 mm)

Rope Length: 500 ft. (152 m)
*Optional 550 ft. (168 m) 35 x 7 class rope

Rope Type:
6 x 37 class EIPS IWRC
*Optional 35 x 7 class rotation resistant

Maximum Rope Stowage: 694 ft. (211 m)

Optional H030G-26G Main Hoist

Rope: 650 ft. (198 m)
6 x 37 class rope
Stowage: 1193 ft. (355 m)

RT700E

specifications

4

Carrier

Chassis

Box section frame fabricated from high-strength, low alloy steel. Integral outrigger housings and front/rear towing and tie down lugs.

Outrigger System

Four hydraulic telescoping single-stage double box beam outriggers with inverted jacks and integral holding valves. Three position settings, 100%, 50% and fully retracted. All steel fabricated, quick-release type round outrigger floats, 24 in. (610 mm) diameter. Maximum outrigger pad load: 80,700 lbs (36,606 kg).

Outrigger Controls

Controls and crane level indicator located in cab.

Engine

Cummins QSB 5.9L diesel, six cylinders, turbocharged, 240 bhp (179 kW) (Gross) @ 2,500 rpm. Maximum torque: 730 ft. lbs. (990 N-m) @ 1,500 RPM.

Fuel Tank Capacity

72 gallons (273 L)

Transmission

Spicer powershift with 6 forward and 6 reverse speeds (3 speeds high and 3 speeds low). Front axle disconnect for 4 x 2 travel.

Electrical System

Two 12-volt maintenance free batteries. 12-volt starting and lighting, circuit breakers, battery disconnect switch.

Drive

4 x 4

Steering

Fully independent power steering:

Front: Full hydraulic, steering wheel controlled.

Rear: Full hydraulic, switch controlled.

Provides infinite variations of 4 main steering modes: front only, rear only, crab and coordinated.

Rear steer centered indicating light.

4 wheel turning radius - 22 ft. 2 in. (6.7 m).

Axles

Front: Drive/steer with differential and planetary reduction hubs rigid-mounted to frame.

Rear: Drive/steer with differential and planetary reduction hubs pivot-mounted to frame.

Automatic full hydraulic lockouts on rear axle permit 8 in. (203 mm) oscillation only with boom centered over the front.

Brakes

Full hydraulic split circuit brakes operating on all wheels. Spring-applied, hydraulically released axle-mounted parking brake.

Tires

29.5 x 25 - 28PR bias earthmover type.

*29.5R25 radial earthmover type.

Lights

Full lighting package including turn indicators, head, tail, brake and hazard warning lights.

Maximum Speed

23 MPH (37 km/h).

Gradeability (Theoretical)

75% (Based on 89,000 lbs. [40 370 kg] GVW) 29.5 x 25 tires, pumps engaged, 110 ft. (33.6 m) boom, and bi-fold extension.

Miscellaneous Standard Equipment

Full width steel fenders, dual rear view mirrors, hookblock tiedown, electronic back-up alarm, light package, front stowage well, tachometer, rear wheel position indicator, 36,000 BTU hot water heater, hoist mirrors, engine distress A/V warning system. Auxiliary hoist control valve arrangement (less hoist). Cold start aid and immersion type engine block heater, 120V 1500 watt.

*Optional Equipment

*Auxiliary Hoist Package (includes Model HO30G-16G auxiliary hoist with electronic hoist drum rotation indicator, hoist drum cable follower, 500 ft. (152 m) of 3/4 in. (19 mm) 35 X 7 class wire rope, auxiliary single sheave boom nose.)

*AIR CONDITIONING PACKAGE (includes hydraulic driven 28,500 BTU air conditioning)

*Auxiliary Lighting Package (includes cab mounted amber flashing light, 360° rotation spotlight and dual base boom mounted floodlights)

*CONVENIENCE PACKAGE (includes in cab LMI light bar)

*"CE" Mark Conformance (includes European boom, battery disconnect switch, 3rd wrap indicator, electric emergency auxiliary steering, dual axis joystick controllers)

*Cross axle differential locks (front and rear)

*Full-length aluminum decking

*Manual pump disconnect

*Pintle hook - rear

*360 degree NYC style positive swinglock

*Rubber mat for stowage trough

*PAT datalogger

*Aluminum fender protectors

**Denotes optional equipment*

RT700E

GROVE.

dimensions

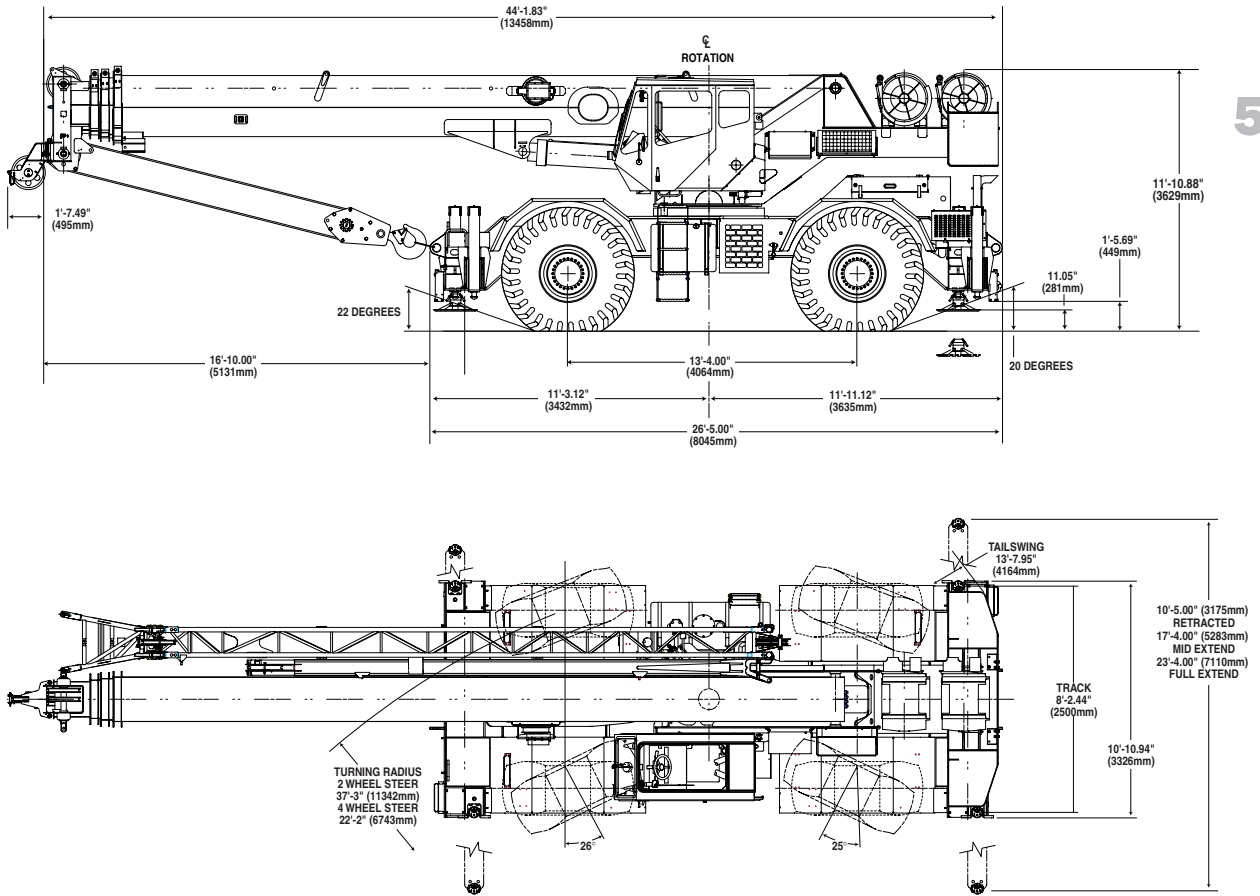

Note: () Reference dimensions in mm

Weights

	GVW		Front		Rear	
	lb.	kg	lb.	kg	lb.	kg
RT700E Basic Machine	84,801	38,466	40,719	18,470	44,082	19,996
ADD: 33 - 56 ft. bi-fold swingaway	2,480	1,125	3,968	1,800	-1,488	-675
ADD: 33 ft. swingaway	1,730	785	3,082	1,398	-1,352	-613
ADD: Auxiliary hoist cable	625	284	-230	-104	855	388
ADD: Auxiliary boom nose	130	59	374	170	-244	-111
ADD: 60 ton (55 mt) 5-sheave hookblock (stowed in trough)	1,250	567	1,250	567	0	0
ADD: 50 ton (45 mt) 3-sheave hookblock (stowed in trough)	1,000	454	1,000	454	0	0
ADD: 8.3 ton (7.5 mt) headache ball (hanging from aux. nose)	370	168	602	273	-232	-105
Remove: Counterweight	-12,150	-5,511	4,784	2,170	-16,934	-7,681

RT700E

working range

Working range – 110 ft. Main Boom & 33-56 ft. bi-fold swingaway

6

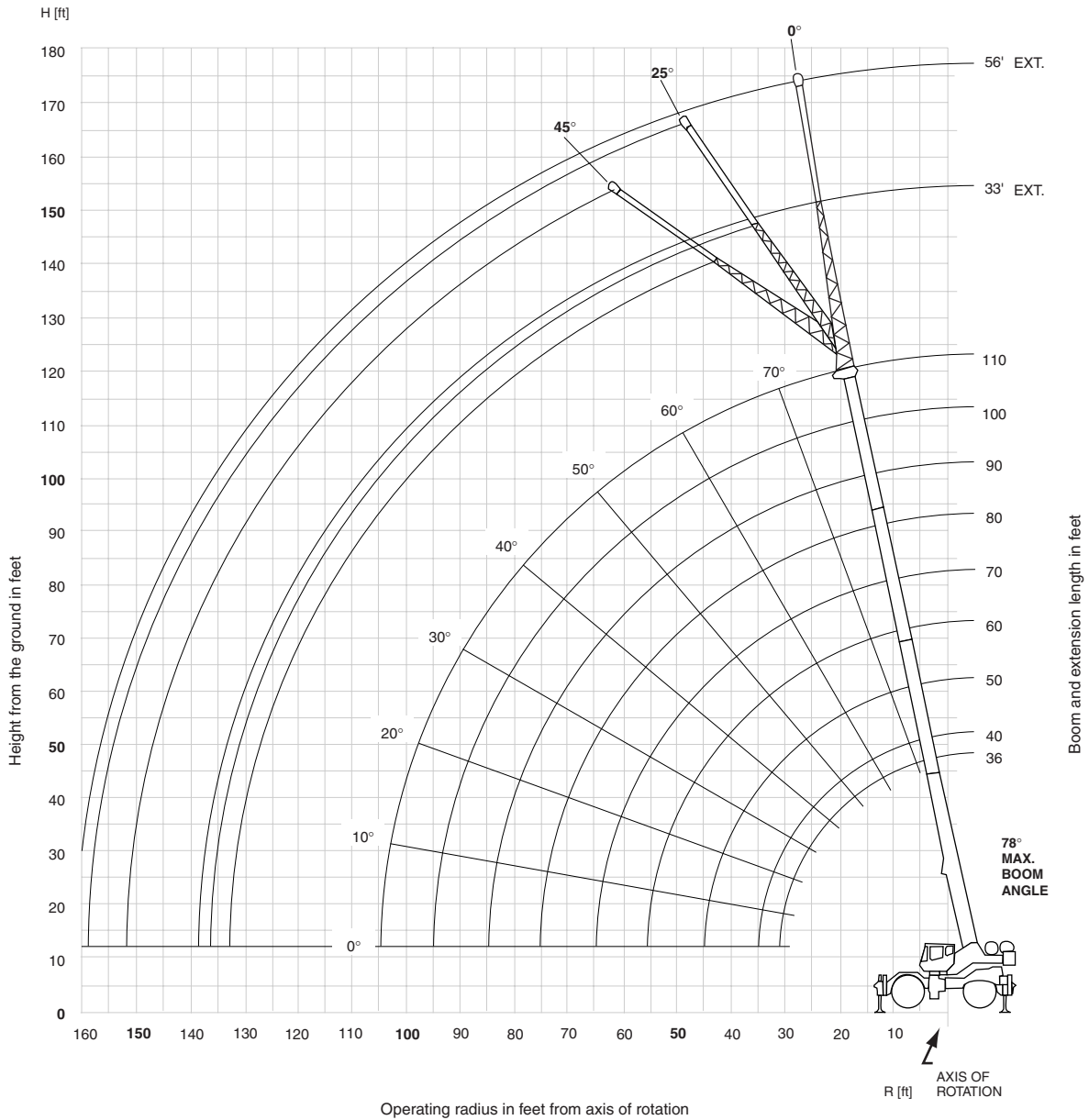

RT700E

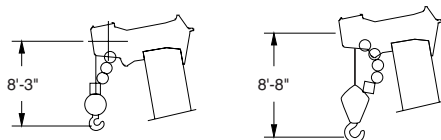

Dimensions are for largest Grove furnished hook block and headache ball, with anti-two block activated.

THIS CHART IS ONLY A GUIDE AND SHOULD NOT BE USED TO OPERATE THE CRANE. The individual crane's load chart, operating instructions and other instructional plates must be read and understood prior to operating the crane.

GROVE

RT750E load chart

 36 - 110 ft.
  12,150 lbs
  100%
  360°
 23 ft. 4 in. spread

Feet	36	40	50	**60	70	80	90	100	110
10	100,000 (69)	84,400 (72)	80,200 (76)	*62,500 (78)					
12	100,000 (65.5)	84,400 (68.5)	80,200 (73.5)	62,500 (77)	*36,800 (78)				
15	85,400 (59.5)	82,700 (63.5)	80,200 (70)	61,000 (74)	36,800 (76.5)	*36,800 (78)	*31,000 (78)		
20	65,700 (49)	65,000 (55)	64,300 (63.5)	50,650 (69)	36,800 (72)	36,800 (75)	31,000 (77)	*29,100 (78)	*24,000 (78)
25	52,800 (36)	52,450 (45)	51,850 (56.5)	41,800 (63.5)	36,800 (68)	34,000 (71)	30,000 (73.5)	27,000 (76)	24,000 (77.5)
30		42,150 (31.5)	39,600 (48.5)	38,000 (57.5)	33,400 (63)	29,000 (67)	25,300 (70.5)	24,200 (72.5)	22,000 (75)
35			31,750 (40)	29,750 (51.5)	28,700 (58)	25,000 (63)	22,200 (67)	21,750 (69.5)	20,000 (72)
40			24,450 (28)	24,750 (45)	23,600 (53)	22,000 (59)	20,200 (63)	19,000 (66.5)	18,500 (69)
45				19,750 (37)	19,700 (47.5)	18,800 (54.5)	17,800 (59.5)	17,300 (63)	17,300 (66.5)
50				16,000 (26.5)	16,750 (41)	16,500 (49.5)	16,000 (55.5)	16,000 (60)	16,000 (63.5)
55					13,650 (33.5)	14,300 (44.5)	14,100 (51)	14,100 (56.5)	14,100 (60)
60					11,150 (24)	12,000 (38.5)	12,200 (47)	12,200 (52.5)	12,200 (57)
65						10,100 (31.5)	10,800 (42)	10,600 (48.5)	10,600 (53.5)
70						8,480 (22.5)	9,410 (36.5)	9,000 (44.5)	9,000 (50)
75							8,100 (30)	7,800 (40)	7,800 (46.5)
80							6,920 (21.5)	6,600 (34.5)	6,600 (42.5)
85								5,800 (28.5)	5,800 (38)
90								5,000 (20.5)	5,000 (33)
95									4,440 (27.5)
100									3,880 (19.5)
Minimum boom angle (°) for indicated length (no load)									0
Maximum boom length (ft.) at 0° boom angle (no load)									110

NOTE: () Boom angles are in degrees.
 #LMI operating code. Refer to LMI manual for operating instructions.
 *This capacity is based on maximum boom angle.

Lifting Capacities at Zero Degree Boom Angle On Outriggers Fully Extended - 360°

Boom Angle	Main Boom Length in Feet								
	36	40	50	**60	70	80	90	100	110
0°	29,050 (29.8)	24,450 (34.2)	17,050 (44.2)	11,950 (54.6)	9,400 (64.2)	7,310 (74.2)	6,050 (84.2)	4,660 (94.2)	3,350 (104.2)

NOTE: () Reference radii in feet.

** Boom length is with inner-mid fully extended and outer-mid & fly fully retracted.

A6-829-101070

7

RT700E

THIS CHART IS ONLY A GUIDE AND SHOULD NOT BE USED TO OPERATE THE CRANE. The individual crane's load chart, operating instructions and other instructional plates must be read and understood prior to operating the crane.

GROVE

RT760E load chart

 36 - 110 ft.
  12,150 lbs
  100%
  360°

23 ft. 4 in. spread

8

Feet	36	40	50	**60	70	80	90	100	110
10	120,000 (69)	84,400 (72)	80,200 (76)	*62,500 (78)					
12	100,000 (65.5)	84,400 (68.5)	80,200 (73.5)	62,500 (77)	*36,800 (78)				
15	85,400 (59.5)	82,700 (63.5)	80,200 (70)	61,000 (74)	36,800 (76.5)	*36,800 (78)	*31,000 (78)		
20	65,700 (49)	65,000 (55)	64,300 (63.5)	50,650 (69)	36,800 (72)	36,800 (75)	31,000 (77)	*29,100 (78)	*24,000 (78)
25	52,800 (36)	52,450 (45)	51,850 (56.5)	41,800 (63.5)	36,800 (68)	34,000 (71)	30,000 (73.5)	27,000 (76)	24,000 (77.5)
30		42,150 (31.5)	39,600 (48.5)	38,000 (57.5)	33,400 (63)	29,000 (67)	25,300 (70.5)	24,200 (72.5)	22,000 (75)
35			31,750 (40)	29,750 (51.5)	28,700 (58)	25,000 (63)	22,200 (67)	21,750 (69.5)	20,000 (72)
40			24,450 (28)	24,750 (45)	23,600 (53)	22,000 (59)	20,200 (63)	19,000 (66.5)	18,500 (69)
45				19,750 (37)	19,700 (47.5)	18,800 (54.5)	17,800 (59.5)	17,300 (63)	17,300 (66.5)
50				16,000 (26.5)	16,750 (41)	16,500 (49.5)	16,000 (55.5)	16,000 (60)	16,000 (63.5)
55					13,650 (33.5)	14,300 (44.5)	14,100 (51)	14,100 (56.5)	14,100 (60)
60					11,150 (24)	12,000 (38.5)	12,200 (47)	12,200 (52.5)	12,200 (57)
65						10,100 (31.5)	10,800 (42)	10,600 (48.5)	10,600 (53.5)
70						8,480 (22.5)	9,410 (36.5)	9,000 (44.5)	9,000 (50)
75							8,100 (30)	7,800 (40)	7,800 (46.5)
80							6,920 (21.5)	6,600 (34.5)	6,600 (42.5)
85								5,800 (28.5)	5,800 (38)
90								5,000 (20.5)	5,000 (33)
95									4,440 (27.5)
100									3,880 (19.5)
Minimum boom angle (°) for indicated length (no load)									0
Maximum boom length (ft.) at 0° boom angle (no load)									110

NOTE: () Boom angles are in degrees.
 #LMI operating code. Refer to LMI manual for operating instructions.
 *This capacity is based on maximum boom angle.

Lifting Capacities at Zero Degree Boom Angle On Outriggers Fully Extended - 360°

Boom Angle	Main Boom Length in Feet								
	36	40	50	**60	70	80	90	100	110
0°	29,050 (29.8)	24,450 (34.2)	17,050 (44.2)	11,950 (54.6)	9,400 (64.2)	7,310 (74.2)	6,050 (84.2)	4,660 (94.2)	3,350 (104.2)

NOTE: () Reference radii in feet.

** Boom length is with inner-mid fully extended and outer-mid & fly fully retracted.

A6-829-101070

RT700E

THIS CHART IS ONLY A GUIDE AND SHOULD NOT BE USED TO OPERATE THE CRANE. The individual crane's load chart, operating instructions and other instructional plates must be read and understood prior to operating the crane.

GROVE

RT700E load chart



9

Pounds						
Feet	33 ft. LENGTH			56 ft. LENGTH		
	0° #0021	25° #0022	45° #0023	0° #0041	25° #0042	45° #0043
30	12,900 (78)					
35	12,900 (76)			*8,330 (78)		
40	12,900 (74)	*10,850 (78)		8,330 (77.5)		
45	12,900 (72)	10,450 (77)	*7,410 (78)	8,330 (76)		
50	12,100 (70)	10,000 (74.5)	7,200 (77.5)	8,330 (74.5)		
55	11,100 (68)	9,220 (72.5)	6,990 (75)	8,250 (73)	*5,300 (78)	
60	10,100 (66)	8,550 (70.5)	6,800 (72.5)	7,540 (71)	5,140 (77)	
65	9,130 (63.5)	7,930 (68)	6,650 (70.5)	7,160 (69)	5,100 (75)	*3,860 (78)
70	8,460 (61.5)	7,380 (65.5)	6,490 (68)	6,820 (67.5)	5,100 (73)	3,790 (77.5)
75	7,840 (59)	6,900 (63)	6,370 (65.5)	6,300 (65.5)	4,800 (71)	3,660 (75)
80	7,230 (56.5)	6,470 (60.5)	6,110 (62.5)	5,810 (63.5)	4,580 (69)	3,550 (73)
85	6,690 (54)	6,070 (58)	5,780 (60)	5,370 (61.5)	4,470 (67.5)	3,450 (71)
90	6,140 (51)	5,720 (55.5)	5,480 (57)	4,980 (59.5)	4,330 (65.5)	3,410 (68.5)
95	5,670 (48.5)	5,400 (52.5)	5,200 (54)	4,630 (57)	4,070 (63)	3,300 (66.5)
100	5,020 (45.5)	5,100 (49.5)	4,950 (51)	4,320 (55)	3,830 (61)	3,260 (64)
105	4,350 (42.5)	4,760 (46.5)	4,650 (47.5)	4,040 (52.5)	3,620 (58.5)	3,220 (62)
110	3,750 (39.5)	4,160 (43)		3,770 (50.5)	3,410 (56)	3,180 (59.5)
115	3,210 (36)	3,600 (39.5)		3,540 (48)	3,230 (53.5)	3,060 (56.5)
120	2,720 (32)	3,100 (35)		3,300 (45.5)	3,050 (51)	2,940 (53.5)
125	2,270 (27.5)	2,640 (30.5)		2,870 (42.5)	2,890 (48.5)	2,800 (50.5)
130	1,860 (22)			2,470 (39.5)	2,730 (45.5)	
135				2,110 (36.5)	2,590 (42.5)	
140				1,770 (33)	2,250 (38.5)	
145				1,460 (29.5)	1,880 (34.5)	
150				1,170 (25)		
Minimum boom angle (°) for indicated length (no load)	21	25	45	25	28	45
Maximum boom length (ft.) at 0° boom angle (no load)		100			90	

NOTE: () Boom angles are in degrees. A6-829-101289
 #LMI operating code. Refer to LMI manual for operating instructions.
 *This capacity is based upon maximum boom angle.

NOTES:

1. All capacities above the bold line are based on structural strength of boom extension and do not exceed 85% of tipping loads, in accordance with SAE J-765.
2. 33 ft. and 56 ft. boom extension lengths may be used for single line lifting service.
3. Radii listed are for a fully extended boom with the boom extension erected. For main boom lengths less than fully extended, the rated loads are determined by boom angle. Use only the column which corresponds to the boom extension length and offset for which the machine is configured. For boom angles not shown, use the rating of the next lower boom angle.
WARNING: Operation of this machine with heavier loads than the capacities listed is strictly prohibited. Machine tipping with boom extension occurs rapidly and without advance warning.
4. Boom angle is the angle above or below horizontal of the longitudinal axis of the boom base section after lifting rated load.
5. Capacities listed are with outriggers fully extended and vertical jacks set only.

RT700E

THIS CHART IS ONLY A GUIDE AND SHOULD NOT BE USED TO OPERATE THE CRANE. The individual crane's load chart, operating instructions and other instructional plates must be read and understood prior to operating the crane.

working range

Working range – 110 ft. Main Boom, Bi-Fold Swingaway & 20 ft. & 40 ft. Inserts

10

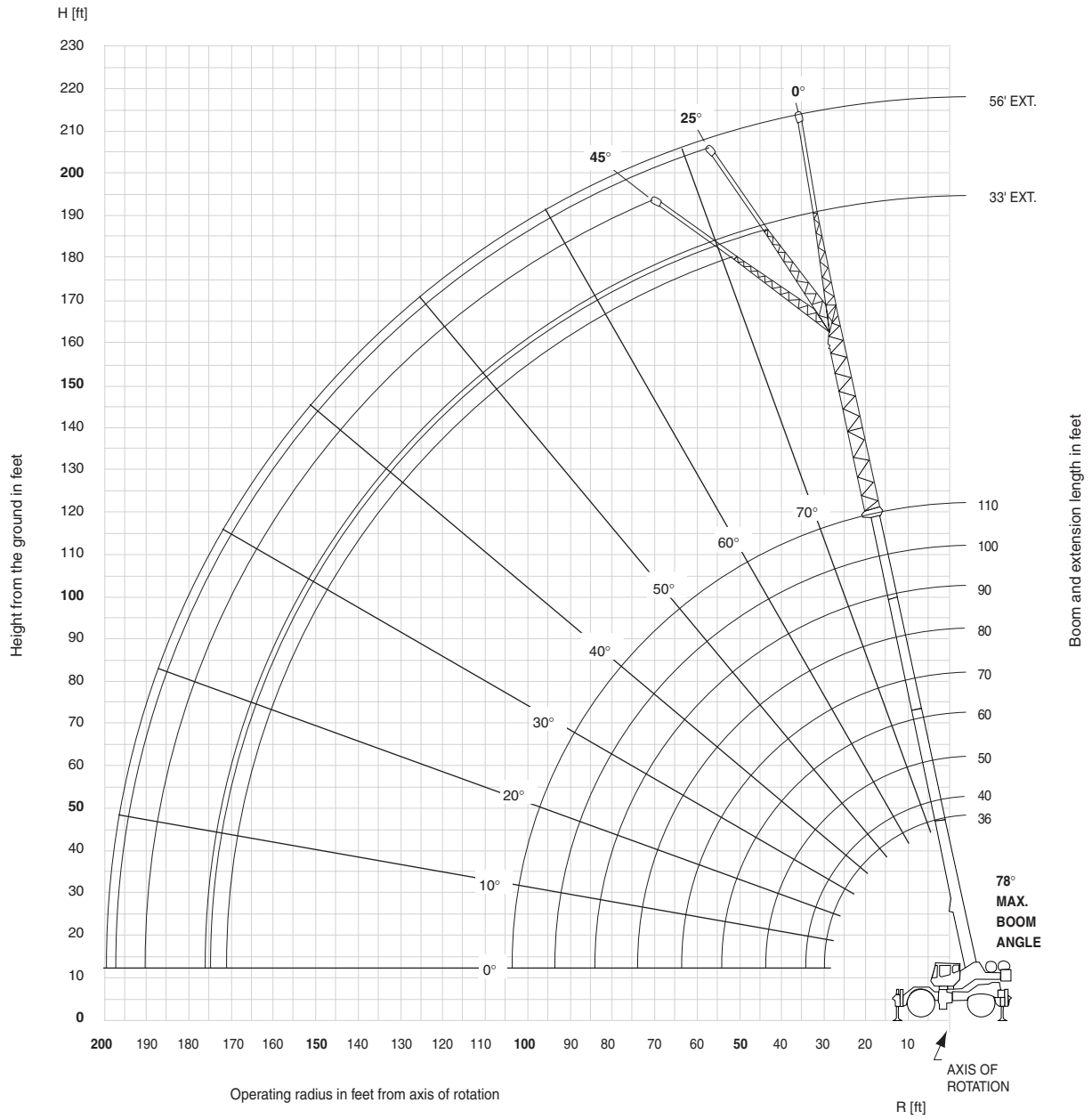

RT700E

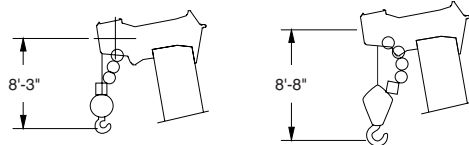

Dimensions are for largest Grove furnished hook block and headache ball, with anti-two block activated.

THIS CHART IS ONLY A GUIDE AND SHOULD NOT BE USED TO OPERATE THE CRANE. The individual crane's load chart, operating instructions and other instructional plates must be read and understood prior to operating the crane.

GROVE

RT700E load chart



11

Pounds						
Feet	33 ft. LENGTH			56 ft. LENGTH		
	0° #0064	25° #0065	45° #0066	0° #0084	25° #0085	45° #0086
35	*9,360 (78)					
40	9,360 (77)			*6,300 (78)		
45	8,480 (75.5)	*7,480 (78)		6,300 (77.5)		
50	7,680 (73.5)	7,070 (77.5)	*5,880 (78)	6,000 (76.5)		
55	6,990 (71.5)	6,470 (76)	5,880 (77.5)	5,990 (75)		
60	6,390 (70)	5,970 (74)	5,480 (76.5)	5,980 (73.5)	*4,840 (78)	
65	5,890 (68)	5,570 (72)	5,080 (74.5)	5,510 (72)	4,840 (77.5)	
70	5,390 (66)	5,070 (70)	4,780 (72.5)	5,010 (70)	4,440 (76.5)	
75	4,990 (64)	4,770 (68)	4,480 (70.5)	4,560 (68.5)	4,050 (74.5)	*3,760 (78)
80	4,650 (62)	4,400 (66)	4,190 (68.5)	4,170 (67)	3,870 (73)	3,460 (76.5)
85	4,300 (60)	4,150 (64)	3,890 (66)	3,820 (65)	3,570 (71)	3,260 (74.5)
90	4,000 (58)	3,850 (62)	3,690 (64)	3,520 (63.5)	3,320 (69.5)	2,960 (73)
95	3,760 (55.5)	3,650 (59.5)	3,500 (61.5)	3,220 (61.5)	3,070 (67.5)	2,770 (71)
100	3,510 (53.5)	3,410 (57.5)	3,300 (59.5)	2,980 (60)	2,880 (66)	2,570 (69)
105	3,260 (51)	3,210 (55)	3,100 (57)	2,780 (58)	2,680 (64)	2,460 (67)
110	3,070 (48.5)	3,020 (52.5)	2,930 (54.5)	2,530 (56)	2,480 (62)	2,340 (65)
115	2,870 (46)	2,870 (50)	2,780 (51.5)	2,340 (54)	2,280 (60)	2,200 (63)
120	2,730 (43.5)	2,730 (47)		2,190 (52)	2,140 (58)	2,050 (60.5)
125	2,530 (40.5)	2,580 (44)		2,000 (50)	1,990 (55.5)	1,910 (58.5)
130	2,210 (37.5)	2,440 (41)		1,850 (48)	1,850 (53.5)	1,810 (56)
135	1,850 (34.5)	2,150 (37.5)		1,720 (45.5)	1,750 (51)	1,670 (53.5)
140	1,510 (30.5)	1,750 (34)		1,610 (43)	1,610 (48.5)	
145	1,200 (26.5)				1,520 (46)	
150					1,370 (43)	
Minimum boom angle (°) for indicated length (no load)	20	25	45	40	41	45
Maximum boom length (ft.) at 0° boom angle (no load)		90		70		

NOTES:

- All capacities above the bold line are based on structural strength of boom extension and do not exceed 85% of tipping loads, in accordance with SAE J-765.
- 33 ft. and 56 ft. boom extension lengths may be used for single line lifting service only.
- For main boom lengths less than 110 ft. with the boom extension erected, the rated loads are determined by boom angle. Use only the column which corresponds to the boom extension length and offset for which the machine is set up. For boom angles not shown, use rating of the next lower boom angle.
- WARNING:** Operation of this machine with heavier loads than the capacities listed is strictly prohibited. Machine tipping with boom extension occurs rapidly and without advance warning.
- Boom angle is the angle above or below horizontal of the longitudinal axis of the boom base section after lifting rated load.
- Capacities listed are with outriggers fully extended and vertical jacks set only.

NOTE: () Boom angles are in degrees.

A6-829-101371A

#LMI operating code. Refer to LMI manual for operating instructions.

*This capacity is based upon maximum boom angle.

RT700E

load chart

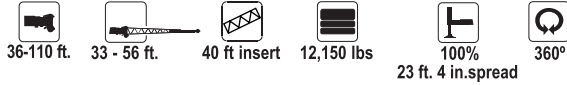

12

Pounds						
Feet	33 ft. LENGTH			56 ft. LENGTH		
	0° #0064	25° #0065	45° #0066	0° #0084	25° #0085	45° #0086
45	6,560 (78)					
50	5,960 (76)			4,510 (78)		
55	5,360 (74.5)	5,860 (78)		4,210 (77.5)		
60	4,860 (73)	5,260 (76.5)	*5,170 (78)	3,910 (76)		
65	4,370 (71)	4,870 (75)	4,670 (77.5)	3,710 (74.5)		
70	3,970 (69.5)	4,370 (73)	4,270 (75.5)	3,410 (73)	*3,710 (78)	
75	3,670 (67.5)	4,070 (71.5)	3,980 (73.5)	3,220 (71.5)	3,420 (77.5)	
80	3,270 (66)	3,670 (69.5)	3,680 (72)	2,820 (70)	3,120 (76)	
85	2,980 (64)	3,370 (68)	3,380 (70)	2,520 (68.5)	2,820 (74.5)	2,730 (77.5)
90	2,780 (62.5)	3,080 (66)	3,080 (68)	2,320 (66.5)	2,620 (72.5)	2,530 (76)
95	2,480 (60.5)	2,880 (64)	2,890 (66)	2,030 (65)	2,330 (71)	2,340 (74.5)
100	2,290 (58.5)	2,580 (62)	2,690 (64)	1,830 (63.5)	2,130 (69.5)	2,140 (72.5)
105	2,090 (56.5)	2,390 (60)	2,390 (62)	1,630 (62)	1,930 (68)	1,940 (71)
110	1,900 (54.5)	2,190 (58)	2,200 (60)	1,440 (60)	1,730 (66)	1,740 (69)
115	1,700 (52.5)	2,000 (56)	2,100 (58)	1,240 (58.5)	1,540 (64.5)	1,550 (67)
120	1,600 (50.5)	1,800 (54)	1,910 (55.5)	1,140 (57)	1,340 (62.5)	1,450 (65)
125	1,410 (48)	1,700 (51.5)	1,710 (53)		1,240 (61)	1,260 (63.5)
130	1,310 (46)	1,510 (49.5)	1,520 (50.5)		1,050 (59)	1,160 (61.5)
135	1,120 (43.5)	1,420 (47)	1,420 (48)			
140	1,030 (41)	1,220 (44.5)				
145		1,130 (41.5)				
150		1,040 (38.5)				
No Load Stability Data						
Min. boom angle at 110' boom length	37°	37°	45°	54°	56°	58°
Max. boom length at 0° boom angle	70 ft.			40 ft.		

NOTE: () Boom angles are in degrees.

A6-829-101581

*This capacity is based upon maximum boom angle.

#LMI operating code. Refer to LMI manual for instructions.

NOTES:

- All capacities above the bold line are based on structural strength of boom extension and do not exceed 85% of tipping loads, in accordance with SAE J-765.
- 33 ft. and 56 ft. boom extension lengths may be used for single line lifting service only.
- For main boom lengths less than 110 ft. with the boom extension erected, the rated loads are determined by boom angle. Use only the column which corresponds to the boom extension length and offset for which the machine is set up. For boom angles not shown, use rating of the next lower boom angle.
- WARNING:** Operation of this machine with heavier loads than the capacities listed is strictly prohibited. Machine tipping with boom extension occurs rapidly and without advance warning.
- Boom angle is the angle above or below horizontal of the longitudinal axis of the boom base section after lifting rated load.
- Capacities listed are with outriggers fully extended and vertical jacks set only.

RT700E

THIS CHART IS ONLY A GUIDE AND SHOULD NOT BE USED TO OPERATE THE CRANE. The individual crane's load chart, operating instructions and other instructional plates must be read and understood prior to operating the crane.

GROVE.

RT700E load charts



Pounds					
#9005					
Feet	Main Boom Length in Feet				
	36	40	50	*60	70
10	45,300 (69)	39,700 (72)			
12	41,750 (65.5)	39,700 (68.5)	29,600 (73.5)		
15	29,350 (59.5)	26,450 (63.5)	26,450 (70)	20,900 (74)	
20	17,800 (49)	17,650 (55)	17,050 (63.5)	16,250 (69)	16,250 (72)
25	11,750 (36)	11,700 (45)	11,350 (56.5)	10,850 (63.5)	10,850 (68)
30		8,040 (31.5)	7,820 (48.5)	7,470 (57.5)	7,470 (63)
35			5,400 (40)	5,120 (51.5)	5,120 (58)
40			3,660 (28)	3,200 (45)	3,430 (53)
45				1,000 (37)	2,150 (47.5)
50					1,150 (41.0)

Lifting Capacities at Zero Degree Boom Angle
On Rubber - Stationary 360

Boom Angle	Main Boom Length in Feet		
	36	40	50
0°	8,180 (29.7)	5,890 (34.2)	2,170 (44.2)

Note: () Reference radii in feet.

A6-829-101048A

#LMI operating code. Refer to LMI manual for instructions.

*60 ft. boom length is with inner-mid extended and outer-mid & fly retracted.



Pounds					
#9005					
Feet	Main Boom Length in Feet				
	36	40	50	*60	70
10	45,300 (69)	42,850 (72)	29,600 (76)		
12	43,650 (65.5)	41,350 (68.5)	29,600 (73.5)		
15	38,300 (59.5)	36,300 (63.5)	29,600 (70)	20,900 (74)	17,300 (76.5)
20	31,150 (49)	29,550 (55)	25,900 (63.5)	20,900 (69)	17,300 (72)
25	24,100 (36)	24,150 (45)	21,800 (56.5)	18,800 (63.5)	17,300 (68)
30		17,400 (31.5)	17,200 (48.5)	15,300 (57.5)	15,300 (63)
35			12,800 (40)	12,500 (51.5)	11,000 (58)
40			9,720 (28)	9,390 (45)	9,390 (53)
45				7,090 (37)	7,090 (47.5)
50				5,310 (26.5)	5,310 (41)
55					3,870 (33.5)
60					3,170 (24)

Lifting Capacities at Zero Degree Boom Angle
On Rubber - Defined Arc Over Front

Boom Angle	Main Boom Length in Feet				
	36	40	50	*60	70
0°	17,600 (29.7)	13,600 (34.2)	7,750 (44.2)	4,010 (54.6)	2,670 (64.2)

Note: () Reference radii in feet.

A6-829-101047

#LMI operating code. Refer to LMI manual for instructions.

*60 ft. boom length is with inner-mid extended and outer-mid & fly retracted.

13

RT700E

load charts

14

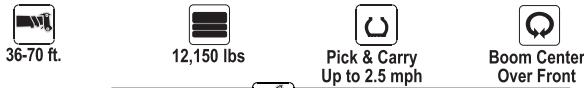

Pounds					
#9006					
Main Boom Length in Feet					
Feet	36	40	50	*60	70
10	42,500 (69)	37,600 (72)	30,700 (76)		
12	42,500 (65.5)	37,600 (68.5)	30,700 (73.5)	23,450 (77)	
15	37,600 (59.5)	37,600 (63.5)	30,700 (70)	19,700 (74)	16,250 (76.5)
20	32,950 (49)	32,900 (55)	30,700 (63.5)	19,700 (69)	16,250 (72)
25	24,100 (36)	24,150 (45)	23,850 (56.5)	19,700 (63.5)	16,250 (68)
30		17,400 (31.5)	17,200 (48.5)	16,800 (57.5)	16,250 (63)
35			12,800 (40)	12,500 (51.5)	12,500 (58)
40			9,720 (28)	9,390 (45)	9,390 (53)
45				7,090 (37)	7,090 (47.5)
50				5,310 (26.5)	5,310 (41)
55					3,870 (33.5)
60					3,090 (24)

Lifting Capacities at Zero Degree Boom Angle On Rubber - Pick & Carry					
Main Boom Length in Feet					
Boom Angle	36	40	50	*60	70
0°	17,600 (29.7)	13,600 (34.2)	7,750 (44.2)	4,010 (54.6)	2,670 (64.2)

Note: () Reference radii in feet. A6-829-101049
 #LMI operating code. Refer to LMI manual for instructions.
 *60 ft. boom length is with inner-mid extended and outer-mid & fly retracted.

NOTES:

- Capacities are in pounds and do not exceed 75% of tipping loads as determined by test in accordance with SAE J765.
- Capacities are applicable to machines equipped with 29.6x25 (28 ply) tires at 65 psi cold inflation pressure.
- Defined Arc - Over front includes 6" on either side of longitudinal centerline of machine (ref. drawing C6-829-003529).
- Capacities appearing above the bold line are based on structural strength and tipping should not be relied upon as a capacity limitation.
- Capacities are applicable only with machine on firm level surface.
- On rubber lifting with boom extensions not permitted.
- For pick and carry operation, boom must be centered over front of machine, mechanical swing lock engaged and load restrained from swinging. When handling loads in the structural range with capacities close to maximum ratings, travel should be reduced to creep speeds.
- Axle lockouts must be functioning when lifting on rubber.
- All lifting depends on proper tire inflation, capacity and condition. Capacities must be reduced for lower tire inflation pressures. See lifting capacity chart for tire used. Damaged tires are hazardous to safe operation of crane.
- Creep - Not over 200 ft. of movement in any 30 minute period and not exceeding 1 mph.

**RIGGING CHART
 INSTALLATION AND REMOVAL OF
 12,000 LB. COUNTERWEIGHT**

ON OUTRIGGERS FULLY EXTENDED - 3600

#0801		
Main Boom Length in Feet		
Feet	*36	40
10	18,000 (69)	18,000 (72)
12	18,000 (65.5)	18,000 (68.5)
15	18,000 (59.5)	18,000 (63.5)
20	18,000 (49)	18,000 (55)
25	18,000 (36)	18,000 (45)
30		18,000 (31.5)

NOTE: () Boom angles are in degrees.
 #LMI operating code. Refer to LMI manual for operating instructions.

Main Boom Length in Feet		
Boom Angle	*36	40
0°	18,000 (29.8)	18,000 (34.2)

NOTE: () Reference radii in feet.
 *Boom must be fully retracted. A6-829-102134

RT700E

load handling

15

Weight Reductions for Load Handling Devices

33 FT. - 56 FT. FOLDING BOOM EXTENSION

*33 ft. Extension (Erected) -	5,080 lb.
*56 ft. Extension (Erected) -	11,330 lb.

FOLDING EXT. WITH 20 FT. INSERT

*33 ft. Extension (Erected) -	11,248 lb.
*56 ft. Extension (Erected) -	19,372 lb.

FOLDING EXT. WITH 40 FT. INSERT

*33 ft. Extension (Erected) -	19,671 lb.
*56 ft. Extension (Erected) -	29,671 lb.

*Reduction of main boom capacities
(no deduct required for stowed boom extension)

When lifting over swingaway and/or jib combinations, deduct total weight of all load handling devices reeved over main boom nose directly from swingaway or jib capacity.

NOTE: All load handling devices and boom attachments are considered part of the load and suitable allowances MUST BE MADE for their combined weights. Weights are for Grove furnished equipment.

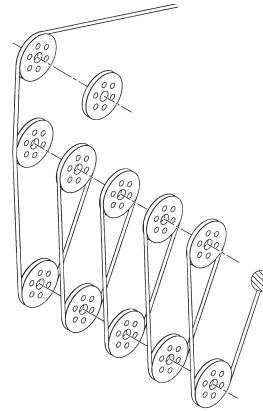

Line Pulls and Reeving Information

AUXILIARY BOOM NOSE	137 lb.
HOOKBLOCKS and HEADACHE BALLS:	
60 Ton, 5 Sheave	1250 lb.+
50 Ton, 4 Sheave	1000 lb.+
50 Ton, 3 Sheave	1000 lb.+
8.3 Ton Headache Ball (non-swivel)	350 lb.+
8.3 Ton Headache Ball (swivel)	370 lb.+

+Refer to rating plate for actual weight.

Line Pulls and Reeving Information

Hoists	Cable Specs	Permissible Line Pulls	Nominal Cable Length
Main	3/4" (19 mm) 6x37 Class, EIPS, IWRC Special Flexible Min. Breaking Str. 58,800 lb.	16,800 lb.	500 ft.
Main & Aux.	3/4" (19 mm) Flex-X 35 Rotation Resistant (non-rotating) Min. Breaking Strength 85,800 lb.	16,800 lb.	500 ft.

The approximate weight of 3/4" wire rope is 1.5 lb./ft.

Hoist Performance

Wire Rope Layer	Hoist Line Pulls Two Speed Hoist		Drum Rope Capacity (ft.)			
	Low Available lb.*	High Available lb.*	16 in. Drum Layer	26 in. Drum Layer	16 in. Drum Total	26 in. Drum Total
1	18,134	9,067	78	78	132	132
2	16,668	8,334	85	164	144	276
3	15,420	7,710	92	256	156	432
4	14,347	7,174	99	356	167	599
5	13,413	6,707	106	462	179	778
6	12,594	6,297	113	575	190	968

*Max. lifting capacity: 6x37 or 35x7 class = 16,800 lb.

Working Area Diagram

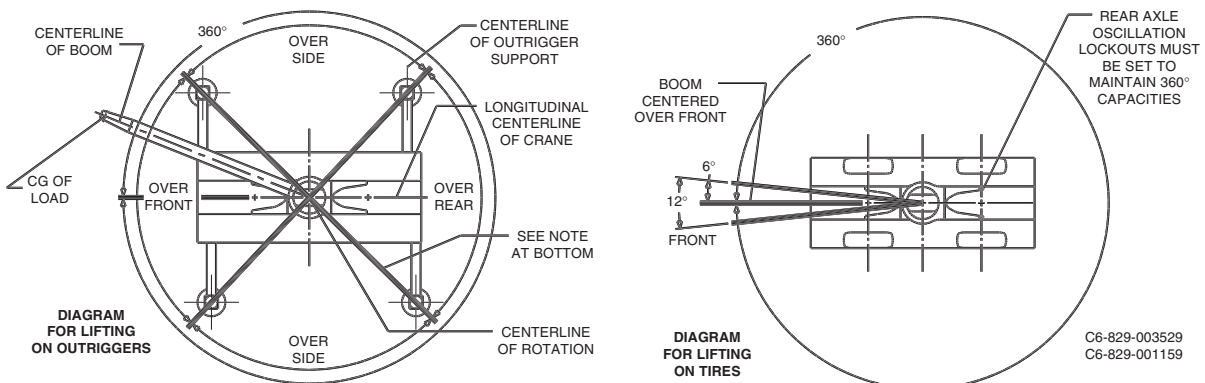

Bold lines determine the limiting position of any load for operation within working areas indicated.

THIS CHART IS ONLY A GUIDE AND SHOULD NOT BE USED TO OPERATE THE CRANE. The individual crane's load chart, operating instructions and other instructional plates must be read and understood prior to operating the crane.



Manitowoc Crane Group - Americas

Manitowoc, Wisconsin Facility
Tel: [Int + 001] 920 684 6621
Fax: [Int + 001] 920 683 6277
Shady Grove, Pennsylvania Facility
Tel: [Int + 001] 717 597 8121
Fax: [Int + 001] 717 597 4062

Manitowoc Crane Group - EMEA

Europe Middle East & Africa
Tel: [Int + 33] (0) 191 565 6281
Fax: [Int + 33] (0) 4 72 18 20 20

Manitowoc Crane Group - UK

Europe Middle East & Africa
Tel: [Int + 44] (0) 191 565 6281
Fax: [Int + 44] (0) 191 564 0442

Manitowoc Crane Group - Germany

(Sales, Parts & Service)
Tel: [Int + 49] (0) 2173 8909 0
Fax: [Int + 49] (0) 2173 8909-30

Manitowoc Crane Group - France

France & Africa (Sales, Parts & Service)
Tel: [Int + 33] (0) 1 303 13150
Fax: [Int + 33] (0) 1 303 86085

Manitowoc Crane Group - Netherlands

(Sales, Parts & Service)
Tel: [Int + 31] (0) 76 578 39 99
Fax: [Int + 31] (0) 76 578 39 78

Manitowoc Crane Group - Italy

Italy & Southern Europe (Sales, Parts & Service)
Tel: [Int + 39] (0) 331 49 33 11
Fax: [Int + 39] (0) 331 49 33 30

Manitowoc Crane Group - Portugal

Portugal & Spain (Sales, Parts & Service)
Tel: [Int + 351] (0) 22 968 08 89
Fax: [Int + 351] (0) 22 968 08 97

Manitowoc Crane Group - Singapore

Asia/Pacific excl China (Sales, Parts & Service)
Tel: [Int + 65] 6861 1733
Fax: [Int + 65] 6862 4040 / 4142

Manitowoc Crane Group - Shanghai

China (Sales, Parts & Service)
Tel: [Int + 86] (0) 21 64955555
Fax: [Int + 86] (0) 2164852038

Manitowoc Crane Group - Beijing

China (Sales, Parts & Service)
Tel: [Int + 86] (0) 10 646 71690
Fax: [Int + 86] (0) 10 646 71691

Manitowoc Crane Group - Middle East

Sales
Tel: [Int + 971] (0) 4 348 4478
Fax: [Int + 971] (0) 4 348 4478
(Parts & Service)
Tel: [Int + 973] (0) 9 660 899
Fax: [Int + 973] (0) 2 707 740

Distributed By:



www.manitowoccrane.com



Constant improvement and engineering progress make it necessary that we reserve the right to make specification, equipment, and price changes without notice. Illustrations shown may include optional equipment and accessories, and may not include all standard equipment.